

POWDER: Platform for Open Wireless Data-driven Experimental Research

Joe Breen^{a,f}, Andrew Buffmire^{b,f}, Jonathon Duerig^{c,f}, Kevin Dutt^{d,f}, Eric Eide^{c,f},
Anneswa Ghosh^{c,f}, Mike Hibler^{c,f}, David Johnson^{c,f}, Sneha Kumar Kasera^{c,f}, Earl Lewis^{e,f},
Dustin Maas^{c,f}, Caleb Martin^{g,h}, Alex Orange^{c,f}, Neal Patwari^{g,h}, Daniel Reading^{c,f},
Robert Ricci^{c,f}, David Schurig^{b,f}, Leigh B. Stoller^{c,f}, Allison Todd^{g,h}, Jacobus Van der Merwe^{c,f,*},
Naren Viswanathan^{b,f}, Kirk Webb^{c,f}, Gary Wong^{c,f}

^a University of Utah, Center for High Performance Computing, USA

^b University of Utah, College of Engineering, USA

^c University of Utah, School of Computing, USA

^d Utah Education and Telehealth Network, USA

^e University of Utah, University Information Technology, USA

^f Salt Lake City, UT, USA

^g Washington University in St. Louis, McKelvey School of Engineering, USA

^h St. Louis, MO, USA

ARTICLE INFO

Keywords:

Mobile and wireless research platform

ABSTRACT

Through a combination of continued demand, technological advancement and regulatory change, mobile and wireless networking is entering an expected period of rapid and broad innovation and change. This landscape presents mobile and wireless researchers with unique and unparalleled opportunities, but the inherent complexity of the wireless ecosystem also presents unique challenges. Specifically, the envisioned broad advancement of the science of wireless networking requires experimentation at scale in real environments, with control and visibility from the lowest layers of the radio up to the top of the application stack. This paper provides an overview of the Platform for Open Wireless Data-driven Experimental Research (POWDER). POWDER is a city-scale, remotely accessible, end-to-end software defined platform being designed and built to address this need. Compared to other mobile and wireless testbeds POWDER provides advances in scale, realism, diversity, flexibility, and access. We describe the POWDER architecture, building blocks, control framework and experimental workflow. We also describe example research efforts being supported by the platform and its current deployment status.

1. Introduction

The evolution of mobile and wireless networks is being accelerated by a near perfect storm of demand, technological advancement and regulatory change. As we have become accustomed to over the last couple of decades, the growth rates of mobile users, mobile traffic, mobile devices and mobile use cases continue to grow unabated. For example, in their most recent global internet analysis and forecasting report, Cisco Systems estimates that by 2023 70% of the global population will have mobile connectivity, the speed of cellular connections

will more than triple, and more than 300 million mobile applications will be downloaded [1]. These anticipated growth rates are driven by accelerated commercial 5G deployments [2] even as the research community is exploring “5G and beyond” [3,4].

Beyond these somewhat expected advances, the mobile and wireless networking evolution is heavily influenced by a number of key trends. First, the “softwarization” of network functionality (software-defined networking, network function virtualization, network programmability, network virtualization) that has fundamentally changed networking

* Corresponding author at: University of Utah, School of Computing, USA.

E-mail addresses: Joe.Breen@utah.edu (J. Breen), andrew.buffmire@utah.edu (A. Buffmire), duerig@cs.utah.edu (J. Duerig), kdutt@uen.org (K. Dutt), eeide@cs.utah.edu (E. Eide), anneswa.ghosh@utah.edu (A. Ghosh), hibler@cs.utah.edu (M. Hibler), johnsond@cs.utah.edu (D. Johnson), kasera@cs.utah.edu (S.K. Kasera), earl.lewis@utah.edu (E. Lewis), dmaas@cs.utah.edu (D. Maas), crmartin@wustl.edu (C. Martin), alex.orange@utah.edu (A. Orange), npatwari@wustl.edu (N. Patwari), dreading@flux.utah.edu (D. Reading), ricci@cs.utah.edu (R. Ricci), david.schurig@utah.edu (D. Schurig), stoller@flux.utah.edu (L.B. Stoller), allisontodd@wustl.edu (A. Todd), kobus@cs.utah.edu (J. Van der Merwe), naren.viswanathan@utah.edu (N. Viswanathan), kwebb@cs.utah.edu (K. Webb), gtw@flux.utah.edu (G. Wong).

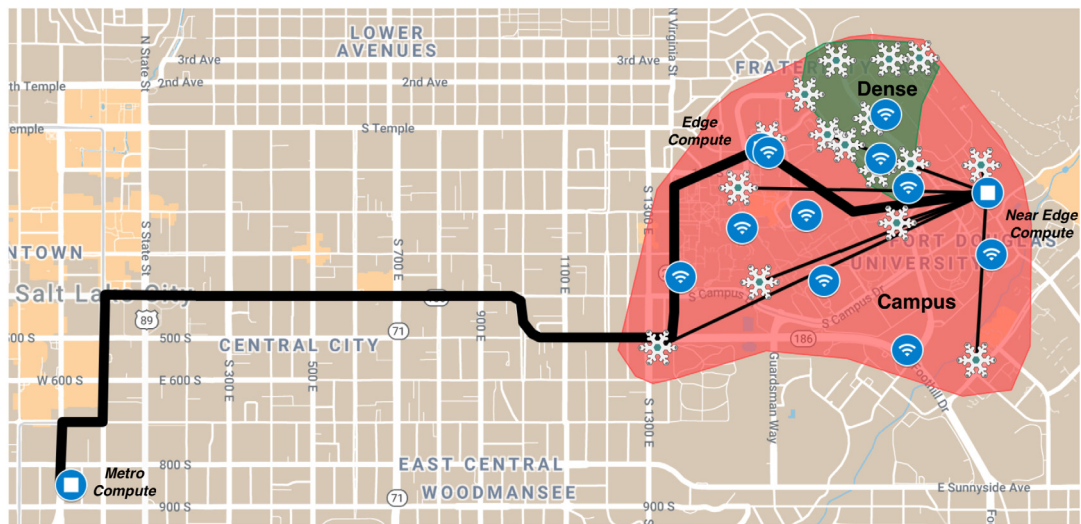

Fig. 1. POWDER footprint. The map shows the existing “Campus” deployment (hilly campus environment), as well as the “Dense” deployment (build-up environment) currently underway. Snowflakes represent “base stations”, while the blue radio emitter nodes represent “fixed-endpoints”. The blue circles with white squares are compute clusters (near-edge, edge and metro), while the black lines are private front/back-haul fiber. (For interpretation of the references to color in this figure legend, the reader is referred to the web version of this article.)

over the last decade is now also being applied to mobile networks in general and the radio access network (RAN) in particular. Specifically, the “Open RAN” concept has evolved from early research prototypes [5] to consortia with broad industry participation [6] and has also attracted interest from regulators [7]. Second, the scarcity of usable spectrum, combined with ever increasing demand for mobile and wireless services and applications, is arguably the biggest challenge associated with the future of wireless and has led to efforts by regulators and funding agencies to emphasize the need for research into innovative spectrum sharing solutions [8–11]. Third, as is the case in many other disciplines, machine learning (ML) technology is being applied to mobile and wireless networking. This includes the application of ML to the analysis and prediction of wireless use [12], to inform the management and operation of ever more complex mobile and wireless networks [13] and indeed to use ML technology to realize different networking functions in a networking stack [14]. Finally, emerging “application level” research associated with, for example, extended reality (XR) [15], volumetric video streaming [16], high precision localization [17] etc., both exploit the capabilities of emerging mobile and wireless networks and drive new capabilities required of future networks.

For researchers in mobile and wireless networking the above trends present unique and unparalleled opportunities for innovation. However, the inherent complexity of the broad mobile and wireless ecosystem also present unique challenges to researchers. Specifically, the advancements demanded by the above trends cannot be attained by tinkering around the edges of existing networks. To drive forward the science of wireless networking, we need innovative researchers to build their own networks at scale and in real environments, with control and visibility from the lowest layers of the radio up to the top of the application stack. I.e., we need *at-scale wireless testbeds*. Since wireless devices are diverse and mobile, the testbed must be too; since technologies change rapidly (and sometimes unpredictably) at all layers of the stack, the platform must likewise be able to adapt to community needs to stay relevant. Such a living laboratory needs to be built with the precision of a scientific instrument so that experimenters can have confidence in the accuracy and reproducibility of their results, and must be built from the ground up to support the scientific process. It must support not only competition in the race for cutting edge technologies, but also cooperation and collaboration that enables researchers and industrial users to build on each others’ work.

This is the vision that is driving the design and realization of the Platform for Open Wireless Data-driven Experimental Research (the POWDER platform) currently being deployed in Salt Lake City, Utah. I.e., POWDER is a **highly flexible city-scale scientific instrument that enables research at the forefront of the wireless revolution**. POWDER is a partnership between the University of Utah, Salt Lake City, and over a dozen other public and private organizations (local, national and global). POWDER is one of the platforms being developed as part of the National Science Foundation (NSF) Platforms for Advanced Wireless Research (PAWR) program. The PAWR program is a public-private partnership between the NSF and an industry consortium of more than thirty organizations.

Designing and realizing the POWDER living laboratory involves addressing many challenges, several of which have contradictory requirements. The challenges include finding practical answers to the following questions: How to support a broad range of research, the experimental needs of which are largely unknown? How to enable an experimental workflow environment that can support such a broad range of research? How to enable research for users who are not physically present at the testbed location? How to ensure experimental repeatability? How to ensure the longevity of the platforms? How to allow safe and compliant radio frequency (RF) transmissions in a real world environment with many other RF services? How to enable multiple users at the same time, and yet prevent interference between experimenters? How to manage platform resources and tools to support many different configurations, without getting overwhelmed by operational complexity?

This paper describes the design and realization of the POWDER platform and the strategies we employ to address these challenges.

POWDER is deploying dozens of programmable radio nodes over an area of approximately four square kilometers. Approximately half of these radios are at fixed locations (“base stations” and “fixed-endpoints”), with approximately forty mobile programmable radio nodes traveling through the area on couriers (“mobile-endpoints”). This space covers two distinct environments: a hilly campus environment and a build-up (urban-like) area (see Fig. 1). The physical deployment also offers a variety of configurable “coverage” scenarios, e.g., conventional macro-cell, or small-cell (enabled by the campus “dense” deployment), or combinations thereof. Diversity in mobility is provided by using mobile couriers that have relatively predictable movement patterns (i.e., campus shuttles, see Fig. 2), and couriers that are “controllable” (e.g., backpacks/portable endpoints that can

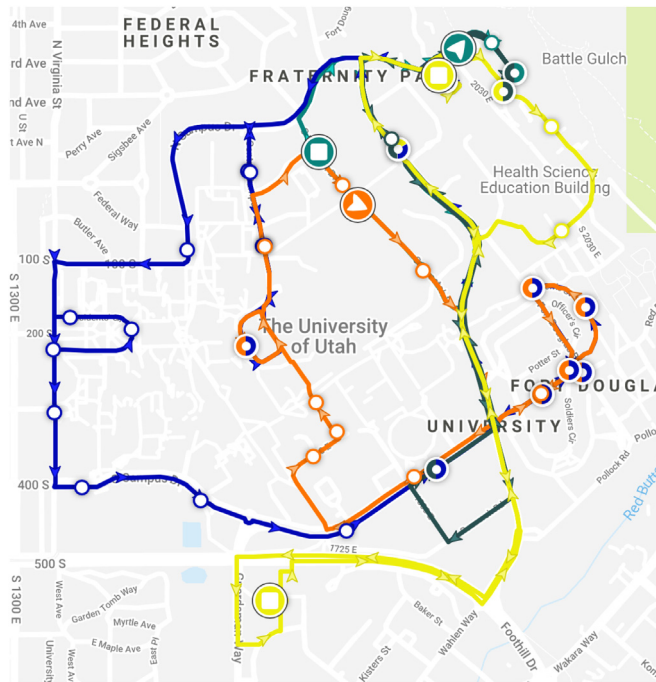

Fig. 2. Routes covered by campus shuttles carrying POWDER mobile-endpoints.

be moved by researchers that come on-site). Each of the deployed nodes consist of user-programmable software defined radios (SDRs), off-the-shelf (OTS) radio equipment, RF front-ends and antennas. Each node is also designed to support a modular “bring-your-own-device” (BYOD) approach whereby experimenters can augment or “replace” functionality in the nodes. All POWDER nodes have out-of-band access so that experimenters can remotely control, monitor, and collect data from their experiments. Nodes also have modest local compute and storage capabilities (i.e., near/edge compute with sub-ms latency), and the ability to access large amounts of cloud computing capacity both in the metro area (with approximately a millisecond of latency) and across the country. Fixed nodes deployed as base stations are connected with each other and compute resources via a dedicated fiber front-haul/back-haul network.

On top of this physical infrastructure, POWDER runs a sophisticated testbed control framework that has build-in support for complex device provisioning and a set of tools for scientific workflow management, collaboration, and artifact sharing. This framework must meet two seemingly contradictory goals: to *provide zero friction between experimenters and raw access to hardware* and to *make it simple for beginners and those who wish to run high-level experiments to get their work done*. Low-level access is necessary for the simple reason that this is where innovations in core wireless communication happen. At the same time, many users, such as those working on wireless service level architectures, for example, do not need to reprogram radios, and are better served by platforms that provide them higher levels of abstraction. The POWDER control framework [18] provides these features. POWDER “profiles” allow one experimenter to run directly on raw hardware, e.g., to explore new wireless waveforms or spectrum management technologies, and another to run a higher-level framework, such as the open network automation platform (ONAP) (www.onap.org), or a complete end-to-end 5G mobile network, on the same platform with equal ease.

POWDER supports a broad range of research areas, including: *Architecture* of next-generation wireless networks (taking advantage of POWDER’s deeply programmable radio, switching and compute resources to explore novel designs in wireless data); strategies for *Dynamic Spectrum access*, using available bands over a wide range of spectrum by

flexibly monitoring and adapting to RF conditions, and exploiting our wideband antennas and SDR transceivers; *Network Metrology* through the measurement of wireless network performance and behavior under varied conditions, throughout the enormous combinatorial space of our multiple locations, flexible hardware, available frequencies, fixed and mobile stations, etc.; and *Applications/Services* with deep end-to-end programmability supporting almost all conceivable application and service models throughout wireless and core networks ranging from lightweight application software on OTS consumer UEs to intensive centralized high-performance computation on our data center resources.

We describe related work in Section 2. A more detailed description of POWDER is provided in Section 3. The POWDER hardware building blocks and example use cases (for which there are existing profiles available) are described in Section 4, and example research efforts by the POWDER team are presented in Section 5. We describe the current status of POWDER in Section 6, and Section 7 concludes.

2. Related work

To our knowledge, there is no existing city-scale outdoor testbed which provides the scale, flexibility and varied scenarios, or which enables the design and evaluation of future networking systems, in the way POWDER does. The fact that POWDER is remotely accessible and open to outside researchers also differentiates it from many earlier testbed efforts.

In terms of indoor wireless testbeds, the ORBIT testbed has been an early and unique resource, enabling wireless research by providing access to stationary nodes deployed in a relatively small area [19]. More recent indoor testbeds include Arena [20] and the Drexel Grid SDR testbed [21]. Another US-based indoor testbed is the PhantomNet controlled RF environment [22], which is being refreshed and integrated into POWDER. In Europe, Fed4Fire+ [23] federates a number of testbeds, including a number of indoor wireless facilities: w-iLab.t is an indoor wireless testbed with a variety of wireless equipment (sensor nodes, WiFi and LTE equipment) [24]. The IRIS [25] and NITOS [26] testbeds provide software defined radios in an indoor environment (similar in functionality to ORBIT). The R2lab is a wireless testbed within an anechoic chamber with OTS and SDR wireless devices [27]. The TRIANGLE project provides 5G application and device benchmarking capabilities [28]. These indoor wireless testbeds do not have the scale and real world conditions available in POWDER.

Earlier US-based outdoor testbeds include DOME [29], CORNET [30], OpenRoads [31], CorteXlab [32], ORBIT outdoor, and Microsoft’s campus bus WLAN service [33]. In Europe the Fed4Fire+ federation includes a number of outdoor wireless testbeds, including: CityLab, a “neighborhood level” smart city testbed [34] with WiFi and IoT equipment and an outdoor instance of NITOS (supporting WiFi, WiMAX and LTE). These earlier outdoor testbeds often lacked the flexibility available in indoor facilities, were relatively small in scope and were typically focused on providing access to specific wireless technologies, e.g., 3G, LTE, WiMax, and WiFi. Several of the earlier outdoor testbeds also were not open to outside researchers. In contrast, POWDER provides a highly flexible end-to-end software defined infrastructure, at city-scale and is open to external researchers.

Recent European efforts also include 5G specific experimental infrastructures, such as 5G-VINNI [35] and 5GENESIS [36]. These infrastructures are focused on 5G specific experimentation with significant industry involvement and using commercial equipment. As such they support a different set of research questions than POWDER, e.g., research associated with application performance or measurements of commercial wireless environments.

The POWDER “sister” projects under the Platforms for Advanced Wireless Research (PAWR) umbrella [37], are closely related to POWDER and share some of the same high-level objectives. The COSMOS platform has a similar high level architecture as POWDER, but with smaller footprint and a specific focus on mmWave technologies [38]. AERPAW is a more recent PAWR platform with a focus on aerial wireless communication [39].

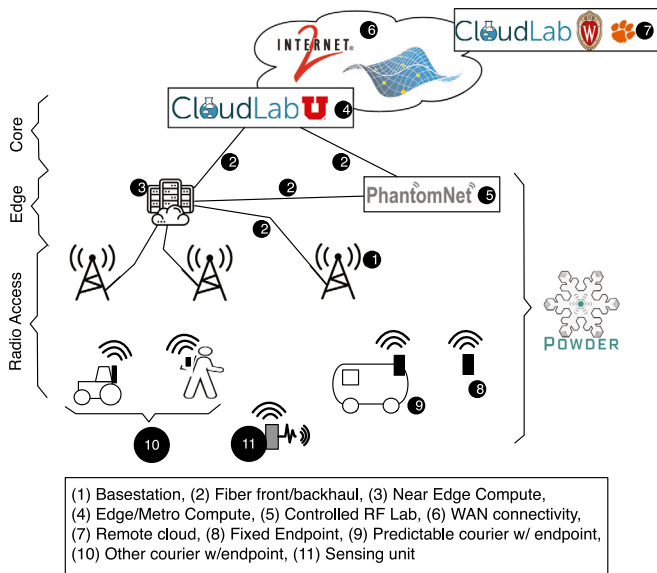

Fig. 3. POWDER Overview and its relationship with other research platforms.

3. POWDER Platform overview

The POWDER architecture is directly driven by current and emerging research needs, and is ready to evolve over time as research questions change. To understand our design, it is helpful to think of it as having three major components: the **physical infrastructure** out of which the facility is built, the **functionality** that infrastructure is designed to provide, and the **control framework** that manages the facility and provides services to users. *Flexibility* and *diversity* are built into the platform at all three levels. The physical infrastructure includes a variety of different types of radios, antennas, environments, and mobility patterns. It is designed so that both general-purpose and specialized equipment can coexist side-by-side, and that BYODes can be added by experimenters. The functionality enabled by these devices is designed to maximize research impact by providing deep programmability end-to-end: from SDRs in the mobile devices and base stations all the way through edge and metro cloud compute platforms. A collection of hardware does not, by itself, constitute a platform for experimentation, so we need a control framework to provision, monitor, and configure the equipment and to provide services to users. By using a control framework that exposes devices at a very low level, users' access to the devices is unfettered, enabling the diversity that will be required to support the large investment in wireless research that is expected in the upcoming years.

3.1. Physical infrastructure

An overview of the physical architecture of the POWDER platform and its relationship with other research platforms is shown in Fig. 3. When fully deployed, POWDER will have tens of *base stations*¹ (#1 in Fig. 3) on the UofU campus. Different areas of the deployment have different densities of base stations. Specifically the UofU campus will have both rooftop base stations as well as more densely deployed base stations at “street level”. (See Fig. 1.) This diversity gives experimenters

¹ The functionality of an SDR is determined by the software executing on it. As such, with the appropriate software *any* SDR can act as a base station, or a wireless endpoint, or a wireless measurement node etc. Nevertheless, for ease of exposition, we use generic wireless terminology, i.e., base station, endpoint etc., to describe the POWDER architecture.

a range of environments and possible configurations in which to run their experiments.

POWDER has two types of base stations. *General purpose base stations* consist of a number of OTS SDRs, an RF front end and antennas, and a complement of control hardware for managing and accessing the devices. (Out-of-band access is provided via the fiber infrastructure describe below.) Specialized *massive multi-input multi-output (mMIMO) base stations* consist of SDRs and antennas in a dedicated configuration to support mMIMO research. Both types of base stations are described in more detail in Section 4.1.

All base stations are fronthauled/backhauled using a dedicated fiber infrastructure (#2) to an *near edge compute cluster* (#3). The near edge compute cluster consist of a rack of general purpose compute and storage servers, within 60 μ s round-trip-time of the base stations. The compute nodes at the near edge compute cluster provide the compute needs of base station SDRs. The edge compute locations are also network aggregation and connection points to the *edge/metro compute platforms* (#4), using 100 Gb/s links. In POWDER the edge compute platform is the existing Emulab cluster [40] on the UofU campus and the metro compute platform is the CloudLab clusters [41] in the UofU downtown datacenter. The Emulab cluster (edge compute) has a round-trip latency of approximately 500 μ s from the base stations, while the CloudLab (metro compute) round-trip latency is approximately 750 μ s. POWDER also connects to, and is federated with, our existing wireless and mobile testbed PhantomNet [22] (#5). PhantomNet provides wireless experimentation in a controlled RF environment, i.e., RF equipment in Faraday cages are interconnected via a software-controlled attenuator matrix. This federation with PhantomNet allows for experiments to be smoothly moved back and forth between a controlled laboratory environment (PhantomNet) and the POWDER living lab. As shown in Fig. 3, together with the other testbeds at the UofU, POWDER connects to Internet2 (#6) to allow federation with other platforms: such as the CloudLab sites at Clemson and Wisconsin (#7) and the GENI “edge cloud” ecosystem. POWDER will also be connected to the programmable national footprint FABRIC infrastructure [42].

The full POWDER deployment will have tens of *wireless endpoints* (#8-10). Wireless endpoints have a similar basic configuration as the general purpose base stations (i.e., SDRs, RF front end and antennas and control infrastructure). They differ from base stations in two regards: Out-of-band access is provided by commercial LTE modem or WiFi (when devices are in range of the UofU campus network), and the computing needs of the endpoint SDRs are provided by small-form-factor compute nodes co-located with the endpoint. Some of the wireless endpoints are deployed at human height at *fixed locations* (#8). Other wireless endpoints will be deployed on a variety of *mobile “couriers”*. There will be two types of couriers: those that can realize *predictable mobility* (#9) and couriers for *controlled mobility* (#10). The predictable couriers are campus shuttles, of which the UofU maintains a large fleet with a variety of on- and off-campus routes. Controlled couriers involve portable endpoints that experimenters can carry or put in vehicles to realize specific mobility objectives. Finally, POWDER will have dozens of IoT sensor units (#11). The sensor units will be deployed both alongside mobile endpoints, and in static locations throughout our wireless coverage area.

3.2. Functionality

General purpose functionality. The physical infrastructure described above becomes **hardware building blocks** in POWDER. As shown in Fig. 4, these hardware building blocks are combined with a variety of **software building blocks** as well as the POWDER **control framework** to realize the overall functionality of the POWDER infrastructure. Using the POWDER control framework (described below in more detail) allows these hardware and software building blocks to be composed into meaningful experiments in the platform

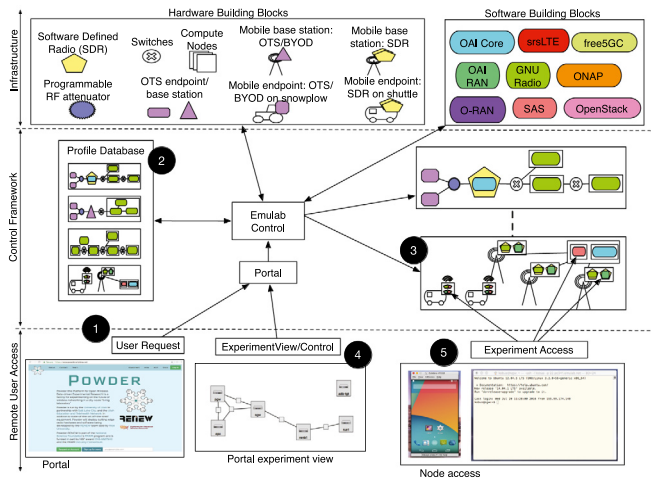

Fig. 4. Functionality and experimental workflow.

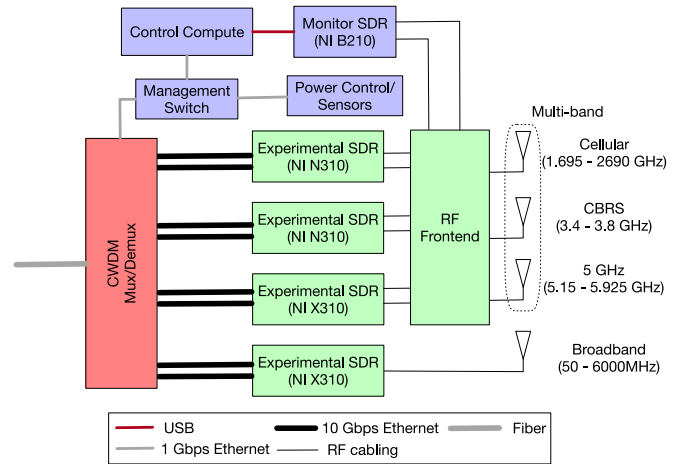

Fig. 5. General purpose base station.

POWDER software building blocks include a variety of SDR stacks (such as GNU Radio [43], OpenAirInterface [44], and srsLTE [45]), core mobile networking stacks (such as free5GC [46], and OpenAir-Interface Core [47], RAN virtualization/programmability stacks (such as O-RAN [6]), connected edge cloud stacks (such as AETHER [48]), as well as general purpose network virtualization and cloud computing stacks (such as OpenStack [49], ONAP [50], and XOS/CORD [51]). The result is that the entire system—endpoints, base stations, networks, and cloud computing infrastructure is software-defined.

The radio equipment in base stations and endpoints is designed to provide wide frequency capability, to provide experimenters with maximum flexibility in selecting propagation characteristics, spectrum licensing authorizations, avoiding interference, and interoperability with existing equipment. Each radio can be allocated to different experimenters, (assuming they operate in non-overlapping spectrum bands), thus allowing multiple experiments to use the same part of the platform concurrently. Alternatively, all radios might be allocated to one experiment where a researcher might use one for the “active” experiment, one for passively monitoring the experiment, and a third for providing frequency interference.

Special purpose functionality. For **extended and customized functionality**, the base stations and mobile endpoints can be expanded with specialized equipment for experiments that cannot be run on the OTS SDRs, such as OTS endpoint equipment (e.g., smartphones or IoT device), BYOD equipment built by experimenters, or specialized devices built by the PAWR industry consortium members. This equipment can use the same control and network infrastructure as the general-purpose SDRs.

As described earlier, specific special-purpose functionality available in POWDER is programmable mMIMO equipment and open source software. The mMIMO equipment derives from the Argos [52] mMIMO technology developed by Rice University and now being commercialized by Skylark Wireless. The mMIMO open source software is being provided by the POWDER “companion project” RENEW (Reconfigurable Eco-system for Next-generation End-to-end Wireless) [53].²

3.3. Control framework

The POWDER control framework is based on the Emulab control framework [40]. Emulab provisions at an extremely low layer, giving

researchers direct access to hardware (as opposed to virtualized or container-based frameworks)—a critical feature for cutting-edge communications design and for systems with real-time requirements. A principal goal of the framework is to provide *zero penalty for remote access*: that is, to make as many features available to remote users as possible so that they can work just as effectively as if they were on-site. In addition to managing user access, experimental resource allocation and experimental control, it provides a *profile* abstraction and support for *scientific workflows*. Profiles capture the relationships and dependencies between building blocks (both hardware and software) making them a key enabler for several important features. First, profiles provide the “recipes” with which the POWDER software and hardware building blocks are combined and instantiated into meaningful end-to-end experiments. Through its profile mechanism POWDER provides a set of functional “one click” experiment environments for popular stacks such as OpenAirInterface and srsLTE for 4G and 5G networks, O-RAN for RAN virtualization and programmability, ONAP for network management, control and orchestration etc. Experimenters can create and share their own profiles, boosting scientific collaboration and repeatability. Second, profiles make it easy to support a range of users, from novices through the foremost experts in the world. Novices can get started using profiles that provide fully functional end-to-end experiments, enabling them to start working right away. Experts can use profiles that provide “raw” access to the equipment: for example, profiles that contain the tools to program SDRs, a task that they would do themselves.

Another valuable property of our control framework is its built-in notions of experiment life cycle and its ability to support sophisticated scientific workflow tools. The language used to describe profiles makes it straightforward to create “parameterized” experiments, enabling experimenters to run different versions of experiments or to do parameter sweeps. For example, starting small and scaling up once an experiment has been shown to work at a small scale, or running repeated trials using the same software but radios in different locations. Profiles are version controlled, meaning that researchers can go “back in time” to run previous versions of their experiments, asking questions such as “are my new results different because of changes to my experiment, or due to external factors?” When publishing results, researchers can also point to the specific version used to gather those results.

The numbered sequence in Fig. 4 depicts the interaction between POWDER components as part of a typical user experimental workflow. Specifically:

(1) Users access the POWDER platform via a portal which, from a user perspective, embodies all aspects of the platform. (2) A user typically selects a profile as the first experimental step. POWDER provides a profile

² POWDER and RENEW are funded as one project from an NSF perspective, the POWDER-RENEW project. POWDER is the platform described in this paper. RENEW involves the development of open source software for the Skylark Wireless mMIMO equipment.

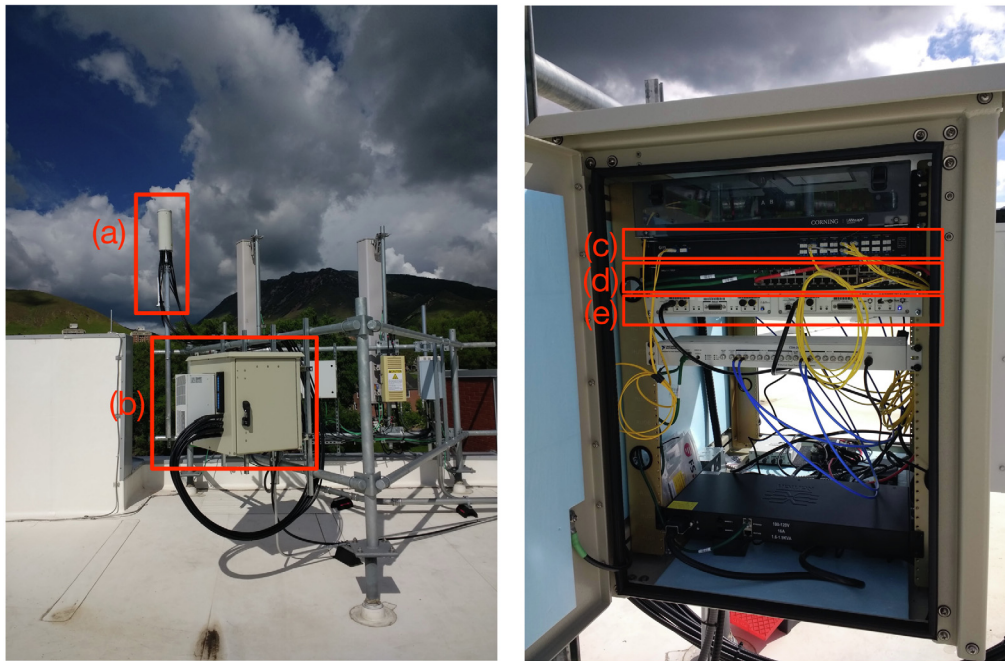

Fig. 6. General purpose base station: (a) Multi-band and broadband antennas, (b) Enclosure, (c) CWDM Mux/Demux, (d) Management switch, (e) Experimental SDRs.

“database”, i.e., existing profiles provided by the platform team or created by users. Profiles describe the hardware and software building blocks that will be used to instantiate an instance of the profile. (3) Once the user has selected (and optionally provided parameters associated with the profile), the POWDER control framework takes over to instantiate an instance of the profile. This includes: (i) Verifying that the profile is syntactically correct. (ii) Determining whether the requested resources, hardware and software, are available. (iii) Allocating the necessary resources for the user. (iv) Loading appropriate software (e.g., operating system images and other profile specific software) on the selected hardware resources. (v) Performing any additional configuration, e.g., network configuration to finalize the profile instance. (4) While the profile is being instantiated the status of the process and details of the resources selected for the experiment is available to the user via the POWDER portal. (5) Once the profile is fully instantiated (an *experiment* in POWDER parlance), the user can access resources in the experiment via the portal. (E.g., by “ssh-ing” into nodes.)

4. POWDER Building blocks

4.1. Hardware

General Purpose Base Station: The general purpose base station components are shown in Fig. 5. Experimental equipment includes four networked SDRs (two NI N310s and two X310s), an RF front-end (supporting frequency division duplex (FDD) and time division duplex (TDD)) and signal amplification. Three of the SDRs are connected to a banded Commscope antenna (VVSP-360S-F). The fourth SDR is connected to a Keysight broadband antenna covering 20 MHz–6 GHz (N6850 A). The experimental SDRs’ 10 Gbps Ethernet links connect to a coarse wavelength division multiplexing (CWDM) multiplexer/demultiplexer (fs.com FMU-C182761M), which is connected via a private fiber run to a complementary CWDM mux/demux unit at the near edge compute cluster which provides general purpose compute capabilities for the SDRs. (The SDRs also contain field programmable gate array (FPGA) functionality which enables radio-local processing.) The base station also contains an NI B210 monitoring SDR which is coupled to the transmit (TX) path of the experimental SDRs (via the RF front end). This allows monitoring [54] of the experimental SDRs

to ensure Federal Communications Commission (FCC) compliance. The remainder of the base station equipment involves a small-form-factor control compute node (which is also the compute node for the monitoring SDR), a management switch, power control and a variety of sensors. As shown in Fig. 6, the base station is housed in a climate controlled enclosure.

Massive MIMO Base Station: Fig. 8 depicts the components of the mMIMO base station [55]. The array is built up of two transceiver SDRs (Skylark IRIS-030-D) that are interconnected to form a chain of SDRs. The SDR chains in turn are connected to an Aggregation Hub (Skylark FAROS-ENC-05-HUB) which serve to interconnect the chains and acts as an aggregation and connection point to the compute platform that gets paired with the base station for mMIMO operation. The base station configuration used in POWDER has four two-transceiver SDRs per chain and eight chains connected to the hub, making a 64-transceiver mMIMO base station. (See Fig. 7.) As shown in Fig. 7, each of the two-transceiver SDRs are front-ended by an RF front end and dual-polarized antenna element (The POWDER configuration is a broadband radio service (BRS)/citizens broadband radio service (CBRS) front end (Skylark IRIS-FE-03-CBRS) capable of operating from 2555 to 2655 MHz and from 3550 to 3700 MHz.)

Endpoint: Fig. 9 shows the base POWDER endpoint design, which is realized on the platform in a number of different configurations, i.e., fixed endpoints, mobile endpoints and portable endpoints. Like the general purpose base station, the main experimental components are SDRs, an RF front end and antenna elements. Endpoints may also include OTS endpoint equipment, e.g., smartphones. (Access to OTS devices is provided via Android Debug Bridge (ADB), which enables user interface access through software such as Vysor (www.vysor.io)). Because they lack high capacity fronthaul/backhaul networks, the experimental compute needs of endpoints are provided by co-located compute elements. Out-of-band access to endpoints is provided via WiFi or commercial LTE. Like the base station design, endpoints have a monitoring SDR (NI B210), coupled to the RF transmission/reception path, to ensure FCC compliance, and control and management elements. POWDER fixed endpoints contain two NI B210 experimental SDRs combined with two Intel NUC small-form-factor compute nodes. Some fixed endpoints have OTS smartphones and others have Skylark Iris SDRs (for interworking with the mMIMO system). Mobile

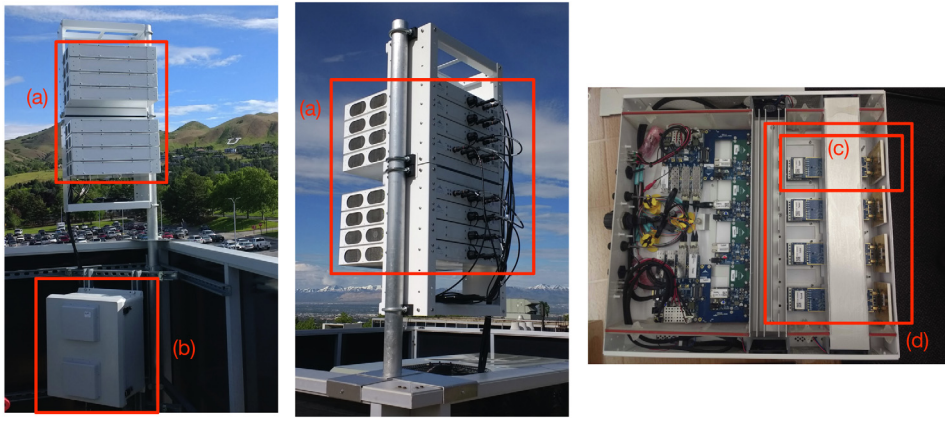

Fig. 7. mMIMO base station: (a) Radio and antenna array, (b) Hub, (c) 2 × 2 Transceiver and antenna, (d) Transceiver chain.

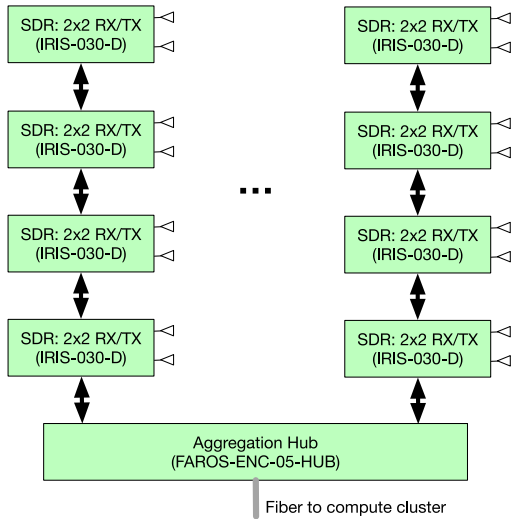

Fig. 8. mMIMO base station (Skylark Wireless).

endpoints contain an NI B210 and NI N300 experimental SDRs, a Xeon-D Mini Server compute node and either OTS endpoint or Iris SDR. Endpoints are equipped with omni-directional wideband antennas (Taoglas GSA.8841 wideband I-bar). Mobile endpoints export their GPS coordinates via a near-real-time interface. (Fig. 10 shows example fixed endpoint and mobile endpoint deployments.) POWDER portable endpoints are designed to be used by experimenters who are physically present at the POWDER platform and want to position the endpoint in a specific manner (e.g., put it in a specific location, or drive along a specific route). Alternatively, the portable endpoints might be used by experimenters who want to bring their own endpoint devices to interact with the platform, but still have “normal” POWDER out-of-band access and experimental control. As such the portable endpoints are being designed to have the same basic access and control features as fixed/mobile endpoints, but to be more configurable in terms of the actual equipment they contain.

RF Front End: Fig. 11 shows the current revision of the front end, which provides LTE Band-7 communication. It provides frequency division duplexing functionality with uplink from 2500 to 2570 MHz and downlink from 2620 to 2690 MHz. Both base station and endpoint front ends are nearly identical in design in this revision. The only difference is that the endpoint has a double pole double throw (DPDT) switch on the frequency domain duplexer (FDD) to provide selection of transmitting on the uplink or downlink frequencies and the base station is hard wired to transmit on the downlink. Power amplification

is the primary component that improves performance. A digitally step attenuator is used to protect the power amplifier from the maximum output power of the SDR it is connected to. The total transmitter gain is about 10–20 dB depending on the radio, tuned to allow saturation of the power amplifier by the SDR without causing damage. On the receive side we use a Low Noise Amplifier (LNA) tuned to the 2500 to 2700 MHz range. There is another digital step attenuator, after the LNA on the receive path, used for gain control. On both the receive and transmit paths a duplexer is connected between the amplifier and the attenuator to provide additional filtering. Finally, a network connected microcontroller (MCU) is used to monitor and control the system. It monitors temperature, voltage and current and controls power voltage per amplifier, bias current of the LNA, attenuators and enables/disables the PA.

4.2. Experimental software & “starter” profiles

POWDER provides low level access to the hardware building blocks described earlier and as such enables a broad range of research without “getting in the way” of platform users. This is clearly a platform strength, i.e., researchers can combine the hardware building blocks in any way they see fit and use *any* software to realize their research. POWDER is, however, a complex environment and this inherent flexibility can be overwhelming to users.

To mitigate this complexity, and to illustrate the range of areas/use cases POWDER supports, we use the *profile* mechanism described earlier to “package” hardware and software building blocks to creating starting points for a range of research [56]:

RF monitoring: The SDRs deployed in POWDER provide an ideal platform for monitoring RF transmissions in a real world environment. RF monitoring is receiving renewed interest because of efforts related to dynamic spectrum sharing [9], sharing between licensed and unlicensed spectrum use [57] and in general efforts related to innovative use of spectrum (e.g., FCC designated Innovation Zones³ [8], exploration of radio dynamic zones [58] etc.) POWDER provides profiles that associate compute and radio equipment, and loads GNU Radio tools [43] to bootstrap this type of work.

Wireless communication: The same low-level access to SDR hardware and software enable wireless communications research. For example, research associated with novel waveforms [59] and coding techniques [60], RF propagation modeling [61], novel wireless architectures [62] etc. The POWDER mMIMO system and software [63] is packaged in a POWDER profile and provides the means to explore questions specific to the coherent use of a large number of antennas

³ POWDER is an FCC Innovation Zone.

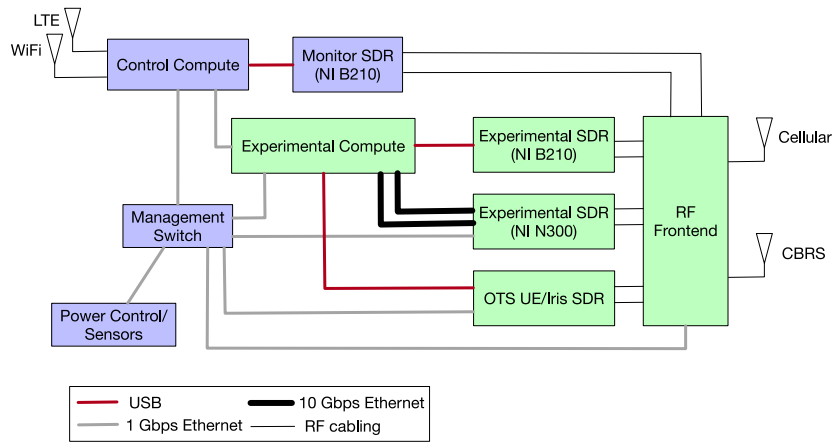

Fig. 9. Endpoint base design packaged in different configurations: fixed endpoints, mobile endpoints and portable endpoints.



Fig. 10. Fixed endpoint & mobile endpoint on campus bus.

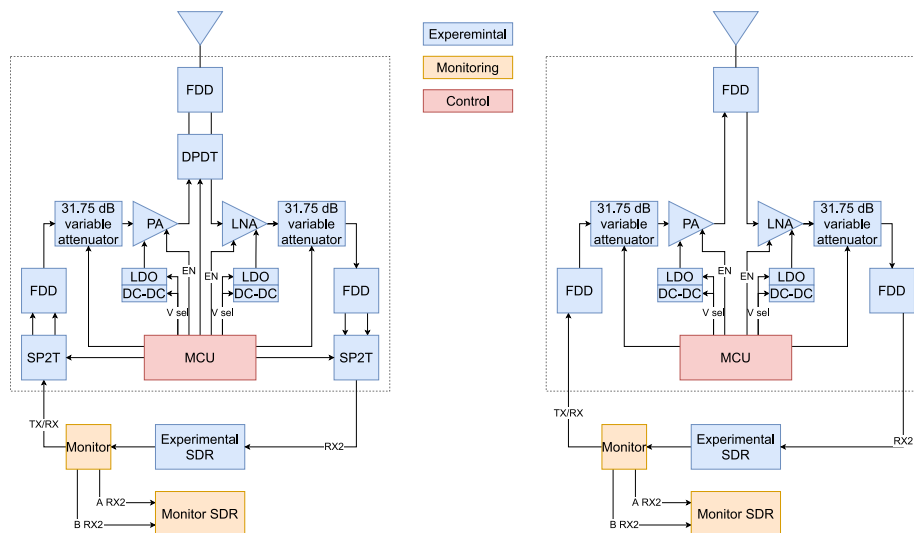

Fig. 11. RF front end: (a) Endpoint, (b) Base station.

and specifically to verify theoretical analyses related to the spectral efficiency of these systems [64]. POWDER also support the examination of numerous practical mMIMO issues, such as the implementation and overhead of pilot signals [65], coding strategies, and initialization procedures for adding users [66].

Mobile communication. The ability to flexibly combine POWDER RF resources with networking and compute resources in the platform enable a broad range of research related to mobile communication. We have numerous profiles associated with open source mobile networking software stacks that provide 4G and 5G functionality, (e.g., srsLTE and OpenAirInterface). The profiles associated with these stacks can be

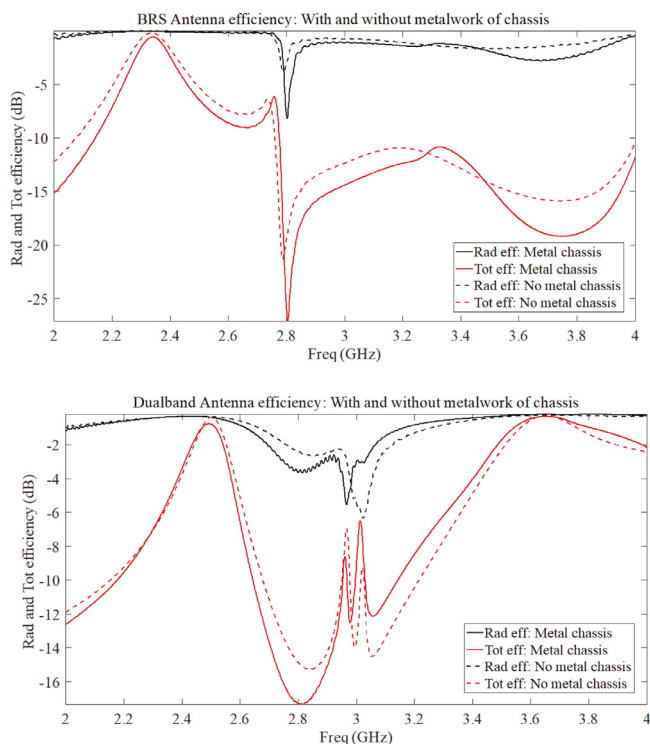

Fig. 12. Top figure: currently deployed single-band antenna. Bottom figure: dual-band antenna.

executed in over-the-air configuration, or using the POWDER controlled RF environment, or using simulated RF communication, thus enabling a range of research configurations [67]. The POWDER profile mechanism can also support sophisticated configurations/topologies associated with network function virtualization and orchestration, technologies that feature strongly in emerging network architectures, including 5G. For example, the POWDER ONAP profile automates the instantiation of this sophisticated industry standard management and orchestration platform.

5. Research examples

In this section we describe example research efforts by the POWDER team to illustrate the utility of the platform.

5.1. BYOD - antenna design

As described earlier in the paper, one of our goals is to enable bring-your-own-device (BYOD) style research in POWDER. While BYOD would typically happen at the granularity of a “complete sub-system”, e.g., a standalone radio unit, where possible we attempt to support finer-grained BYOD approaches. A specific example of the latter involves support for electromagnetic design of antennas as an integral part of wireless network experimentation. We plan to support user-supplied antenna designs, with relatively rapid deployment onto the platform, from CAD to deployment in perhaps as little as a few weeks. The POWDER team can assist with: (i) electromagnetic design validation using industry-standard computation electromagnetics solvers, (ii) interfacing with the fabrication vendor, (iii) network analysis testing in an anechoic chamber, and (iv) antenna integration onto the POWDER platform hardware. Rapid prototyping methods supported can include: 3D printing, circuit board lithography or micro-machining, and CNC wire bending.

To explore the feasibility of BYOD antenna research in POWDER, we have designed a dual-band antenna array for the POWDER massive-MIMO

platform. The goal is to provide platform users access to both an LTE band around 2.5 GHz and the CBRS band, 3.55–3.7 GHz. These two bands will provide significant discrimination in scattering, path-loss, and general RF environment, enabling the testing of coding strategies and algorithms for RF robustness.

The key benefit of doing antenna research on a complete wireless communications system, is that proposed designs can be optimized and tested using system level metrics, rather than only relying on traditional antenna performance parameters, such as S-parameters, directivity and radiation efficiency. For example, maximizing mean spectral efficiency over a statistical ensemble of user endpoint locations and scattering-centers allows one to automatically make quantitatively efficient trade-off decisions between: pattern, polarization, inter-channel coupling, and radiation efficiency. Optimal design parameters obtained with system level metrics also allow quantitative balancing of the performance across two (or more) bands.

Fig. 12 shows simulations of the antenna efficiency of the currently deployed single band antenna (top figure) and the efficiency of our dual-band antenna design (bottom figure). Fig. 13 shows a photo of the manufactured dual-band antenna. The dual-band antennas will be deployed in the POWDER mMIMO system and the BYOD “antenna research workflow” we followed is available to platform users wishing to perform such system level antenna research.

5.2. Spectrum usage and prediction

Increased use of mobile and wireless devices has caused increased demand for wireless spectrum. In some sectors, specifically mobile communication, the increased demand for spectrum is manifest through ever increasing numbers of mobile devices. What is not clear, however, is the extent to which spectrum is actually being used across the overall spectrum range. We performed an initial study to investigate actual spectrum usage in the sub-6 GHz range. (The details of this work can be found in the MS Thesis titled “Spectrum Usage Analyses and Prediction Using LSTM Networks” [12].)

We specifically study spectrum usage in the frequency range 700 MHz to 2.8 GHz in Salt Lake City, Utah. Our study indicates that several portions of these frequencies are under-utilized. Furthermore, we observe that certain frequency bands demonstrate clear usage patterns, e.g., show higher utilization during the daytime compared to night-time; suggesting this behavior can be exploited for opportunistic secondary usage of the spectrum.

Our spectrum usage data was obtained using POWDER fixed-endpoints (described in Section 4.1). We use the Python API provided by the USRP Hardware Driver (UHD) to set the receive gain and to acquire I/Q samples from a specific channel at a specified sample rate. The measured frequency range is divided into bands, each with a width of 30MHz. Each 30MHz band is further divided into 200 points such that the distance between two consecutive frequency points is 150 KHz. These frequency points are represented by the center frequency of the 150 KHz wide channel. The raw data collected for each frequency point is the signal power computed at the USRP. We scan the frequency bands acquiring raw I/Q samples at a sample rate of 30MHz and processing the samples to compute log power for 150 KHz bins.

We collected spectrum data for five days from March 8th, 2020, 11:00 PM to March 13th, 2020, 11:00 PM. The spectrum usage in the frequency range of 700 MHz to 2800 MHz, along with the spectrum allocation categories by the US Department of Commerce, is shown in Fig. 14. We can make the following observations from this figure:

- Low or no occupancy on the following bands: Radio Navigation, Aeronautical Radio Navigation, Earth, Exploration, Space Research, Amateur, Fixed Satellite services.
- 71.4% of bands have 0%–20% usage, 5.7% of bands have 80%–100% usage. Average usage is only 19.08%.
- Several bands (yellow highlights) exhibit significant differences between day (orange bars) and night time (blue bars) spectrum use.

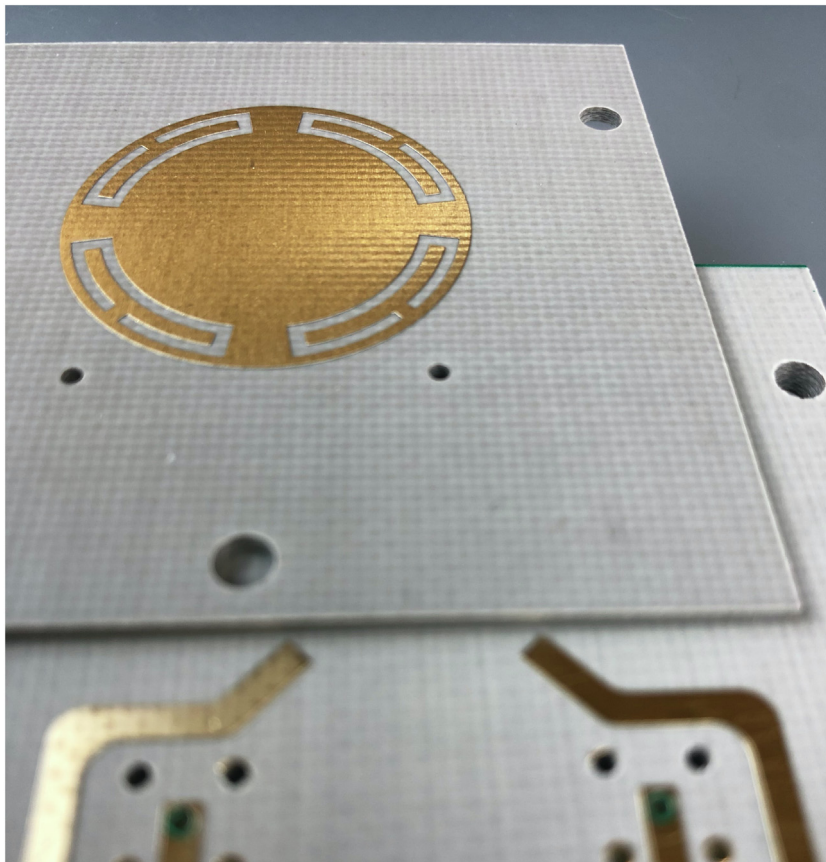

Fig. 13. Dual-band antenna: The top board has the radiating patch, with circumferential slots that differentially tune two resonant modes to the desired frequencies. The bottom board has a non-contact microstrip feed layer that excites the radiating patch.

5.3. Radio channel measurement and modeling

POWDER is capable of being used in large-scale repeatable channel measurement studies. In addition to being frequency-agile, the POWDER platform has a large number of radio nodes, both at rooftop height and at human height. These can be reserved for use in a large channel measurement study, and can be repeatedly used to measure the same exact network in different weather/seasons, interference, and time-of-day conditions.

As an example, we use eight rooftop CBRS nodes, that is, the NI X310 on each rooftop node, to perform a basic path loss measurement experiment [68]. We use one rooftop node at a time as a transmitter, and measured received power at the other seven; then repeat with the next node as transmitter, and repeat until all 7×8 links were measured. Fig. 15 shows the received power (red dots) vs. path length for the 56 links. The dB received power is not calibrated, so is listed as referred to an unknown reference. The path loss exponent model for the measurements (blue line) has a path loss exponent of 3.6 and standard deviation of 8.5 dB. We determine that the measurements fit the path loss exponent model with an exponent of 3.6, that is, that the power decays proportionally to $d^{-3.6}$, where d is the path length. Such path loss models are useful for cellular deployment planning. Improvements in path loss models can help develop deployment plans that ensure sufficient SINR across a network.

POWDER also enables wideband channel impulse response (CIR) measurements which can be used to develop multipath models which then impact physical layer design. For example, as depicted in Fig. 16, we use a pseudo-noise (PN) signal transmitter and a correlation receiver to measure the CIR between two POWDER rooftop nodes (William Browning Building and Behavioral Science Building). Fig. 17 shows the resulting CIR estimate. As expected, we see multipath powers with exponentially

decreasing magnitude as a function of excess time delay. We additionally see a multipath at $8 \mu\text{s}$ with 20 dB less power than the first path. This late-arriving multipath component may be attributed to a reflection from the mountains bordering the University of Utah campus, as seen in the background of the view in Fig. 16.

Cellular operators know that weather changes impact the performance of mobile networks. POWDER provides a unique platform to observe and model temporal changes at a variety of time scales by measuring the same channel over seconds, minutes, hours, days, and seasons, which generally has not been well modeled. We expect that the POWDER platform will enable key new statistical and temporal models which will improve reliability and user experience of 5G cellular and other future generation wireless systems. For example, Fig. 18 plots receive signal strength measurements on a particular POWDER CBRS link, together with the environmental temperature for the corresponding time period.

5.4. RAN programmability

The broad industry trend towards software defined networks is also fundamentally changing the manner in which mobile and wireless networks are being built. The ability to “softwarize” the radio access network (RAN) is of particular interest as it enables innovation in the RAN/multi-access edge compute (MEC)/ultra-low-latency domains. RAN programmability efforts have evolved from early research efforts [5] to more ambitious industry efforts, such as the O-RAN Alliance [6] that is undertaking broad standardization and development in this area.

These efforts to “open up” the RAN, and making RAN systems more programmable, is also readily supported with POWDER’s flexibility and unique mix of resources. We have a number of ongoing efforts in this space, including the following:

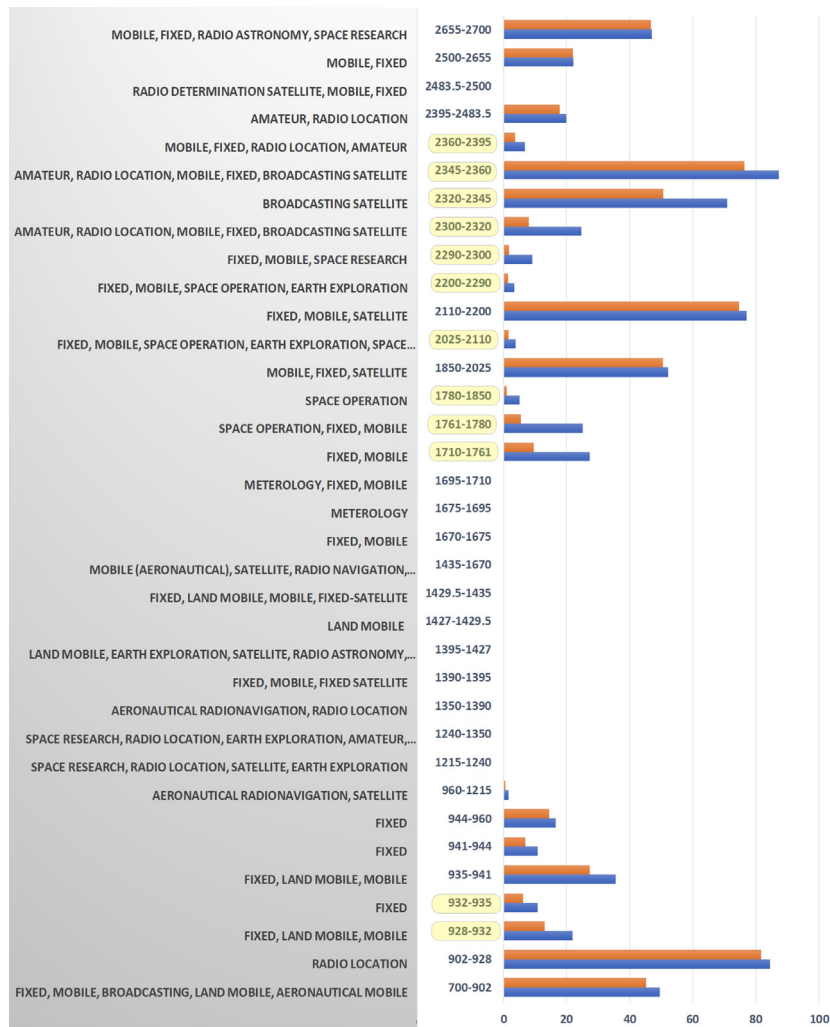

Fig. 14. Spectrum usage. (For interpretation of the references to color in this figure legend, the reader is referred to the web version of this article.)

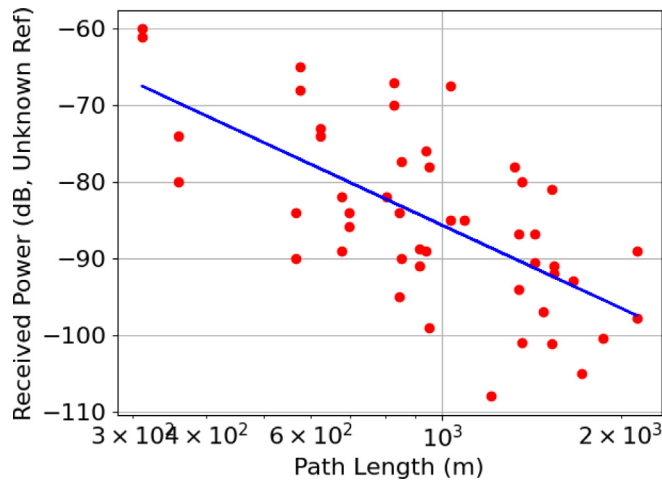

Fig. 15. Received power vs. path length for links between two rooftop nodes in POWDER using a CW transmission at 3.5 GHz.

interface. This provides an open source, fully functional, end-to-end O-RAN capable environment for POWDER users. We maintain a POWDER O-RAN profile which captures the latest version of these efforts. When instantiated, the current O-RAN profile automatically instantiates a Kubernetes cluster (using Kubespray), uses the cluster to set up an O-RAN environment (using the O-RAN Alliance bronze release), configures and starts up an srsLTE environment with an E2 agent implementing the O-RAN KPImon service model.

- *RAN programmability use cases:* The concept of an open/programmable RAN is well accepted by the mobile/wireless community. However, details about exactly how it should be realized (e.g., to ensure latency requirements are met), what data and controls needs to be made available via its interface abstractions (e.g., the granularity of data needed, RAN mechanisms to be controlled) etc., are still open questions. We are exploring various RAN programmability use cases to inform these questions. Including, exposing RAN resources through the E2 interface to enable RAN slicing and fine-grained resource management; applying machine learning to optimize various RAN functions, such as the energy use of battery operated IoT devices, or handover decisions in a heterogeneous RAN environment with overlapping macro/small cells.

- *O-RAN integration with open source mobile stacks:* We are extending the open source mobile stacks we have available on POWDER (i.e., OpenAirInterface and srsLTE), to support the O-RAN E2

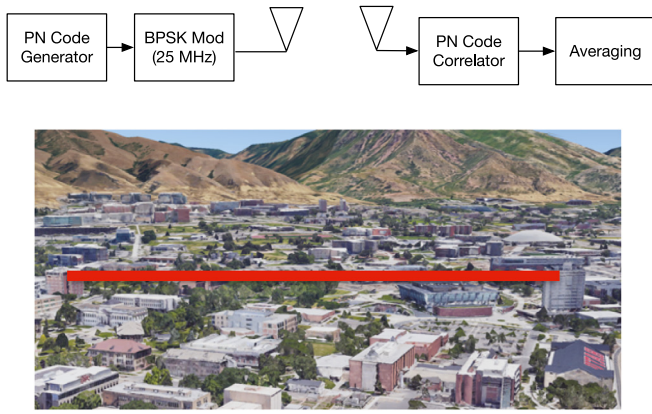

Fig. 16. (Top) Channel impulse response (CIR) measurement setup; (Bottom) Google Earth view of link from the William Browning building to the behavioral science building rooftop nodes.

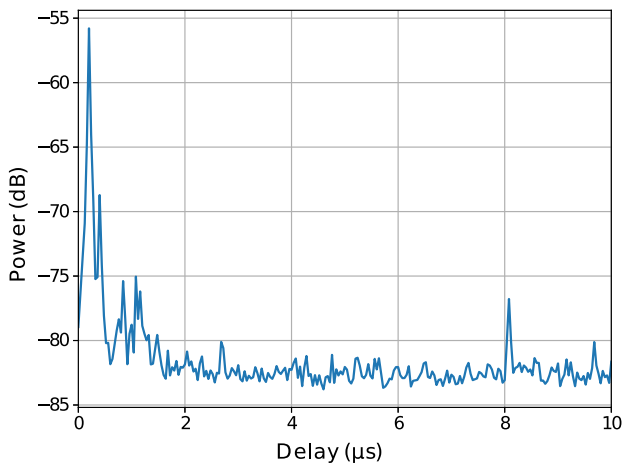

Fig. 17. Example CIR measurement.

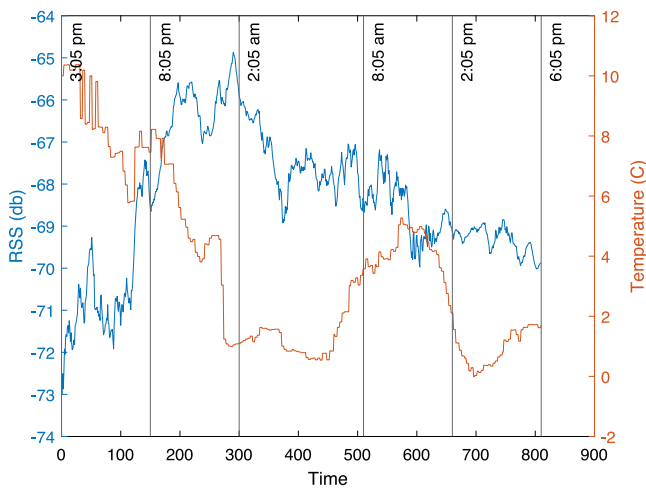

Fig. 18. Received signal strength and environmental temperature on a CBRS link.

5.5. Localization

POWDER is uniquely capable of being used in localization research with its access to mobile and stationary endpoints, rooftop base stations and massive MIMO nodes, as well as its highly accurate time

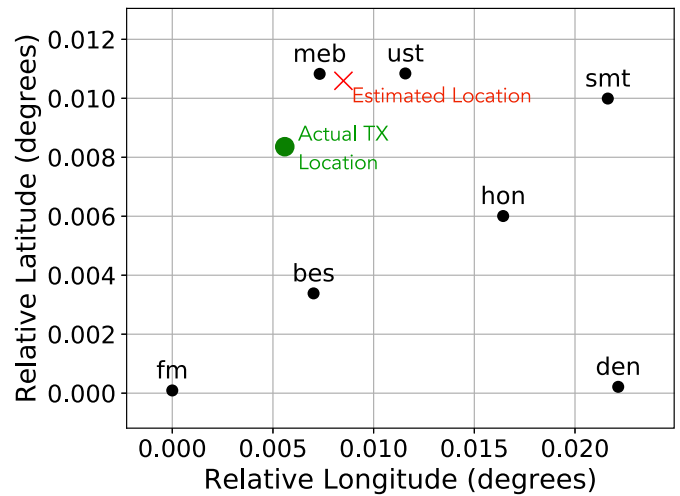

Fig. 19. Actual and estimated location of transmitter from an example localization experiment.

and frequency synchronization capabilities. POWDER enables measurements of received power, angle, and time-of-arrival, and additionally enables scheduled transmission, user-defined transmit power and relative phase, which in combination, allows a broad segment of radio localization research.

GPS coordinates of rooftop nodes and endpoints are available for all nodes in POWDER. These coordinates can be used to find distances between nodes, or to plot on top of maps. For example, Fig. 19 shows the results of a basic POWDER experiment testing transmitter localization using received power measurements. The experiment used seven rooftop nodes as receivers and one as a transmitter. The figure shows the locations of seven rooftop nodes (black dots), in latitude & longitude degrees relative to the Friendship Manor (fm) node. A received power-based localization algorithm provides a transmitter location estimate (X), vs. the actual transmitter location (green dot).

For higher accuracy localization, POWDER will have two systems for time and frequency synchronization of rooftop nodes. First, each rooftop site currently has a GPS-disciplined oscillator driving an Ettus Research OctoClock, which provides 1 pulse-per-second (PPS) and 10 MHz signals to each software-defined radio (SDR) at the site. Second, the POWDER team is evaluating a White Rabbit (WR) time synchronization system which can provide sub-nanosecond level accuracy between rooftop nodes over fiber. WR was developed as an open collaboration to meet the time synchronization needs of large-scale physics experiments such as CERN. At this level of accuracy, time-of-arrival measurements at different rooftop sites can be accurately time-stamped such that range errors from synchronization are on the order of 10 cm. POWDER plans to use the PPS and 10 MHz signals derived from WR for all SDRs in each rooftop site. Thus the phase and time synchronization provides a predictable phase difference between the antennas in the system, such as the elements of the massive MIMO antenna array provided by RENEW. This stable, predictable phase difference could thus be used to estimate angle-of-arrival using measurements on multiple antenna elements. With the WR hardware fully deployed, the GPS-DO would act as a backup in case the WR signals are unavailable.

While no OctoClock currently is deployed at fixed endpoints or mobile endpoints, the POWDER team is developing a GPS-DO clock distribution network for these endpoints. Without endpoint synchronization, one may perform localization using the synchronized rooftop nodes using time difference of arrival (TDOA). The rooftop nodes can synchronously transmit orthogonal signals while the endpoint receiver measures their differences in arrival times (like GPS), or the endpoints can transmit and the rooftop nodes can receive and measure the differences between arrival times (also called *reverse GPS*).

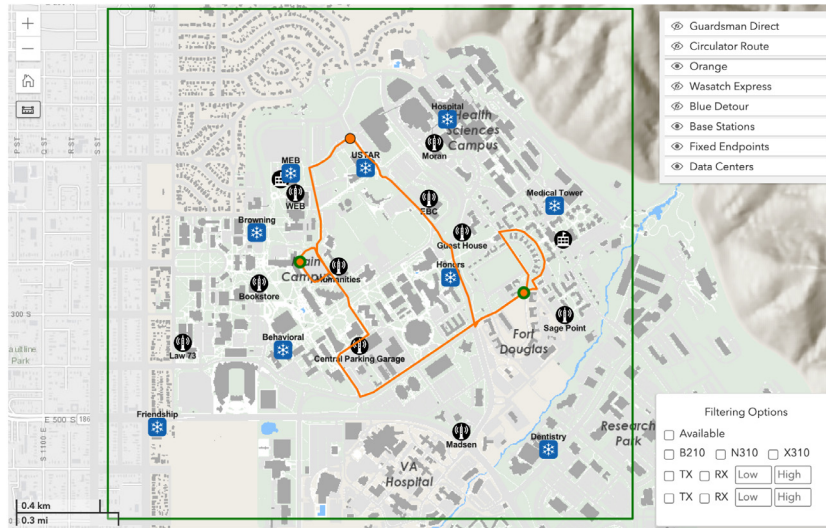

Fig. 20. “Live” map of current POWDER deployment (<https://powderwireless.net/map>). (For interpretation of the references to color in this figure legend, the reader is referred to the web version of this article.)

Time-based localization requires time information to be available to the localization application. Calls to the UHD library allow the clock source (internal oscillator vs. external clock) to be specified. Further, the UHD interface to each SDR allows transmission or reception to be scheduled with regards to the 1 PPS signal, and it also provides time stamp metadata to be recorded along with signal samples.

We expect that these capabilities will allow for highly accurate time-based localization across a variety of TDOA or time-of-arrival (TOA) localization systems, angle-of-arrival systems which require consistent phase across multiple antennas, and power-based localization systems.

6. Status and discussion

Table 1 summarizes of the POWDER deployment status and plans as of April 2021.

Fig. 20 shows a screenshot of (and the URL for) a live map that depicts the current POWDER deployment. The figure shows the “Orange” shuttle route with three buses, two of which (with green circles) are equipped with mobile-endpoints.

While parts of POWDER are still being deployed, the platform has been available for experimenters since November 2019. Between November 1, 2019 and April 17, 2021, there were 115 registered projects, and 57 of those instantiated at least one experiment. These 57 projects represent 447 users who have collectively instantiated 9433 experiments.⁴ Fig. 21 shows a time series of the number of experiments started per day during the time period, and Fig. 22 shows a time series of the cumulative daily experiment duration. Although the time period is too short to draw general conclusions, the graphs suggest an (expected) reduction of activity over the traditional vacation period during December and into January before activity increased again.

Because POWDER is an open platform, we do not control or even know the exact details of the research conducted by POWDER users. However, when users register to make use of POWDER, they provide a brief description of their intended use of the platform. Based on these descriptions we can say that POWDER users *aspire* to do research in a very broad range of topics, including quality and security of mobile data; end-to-end

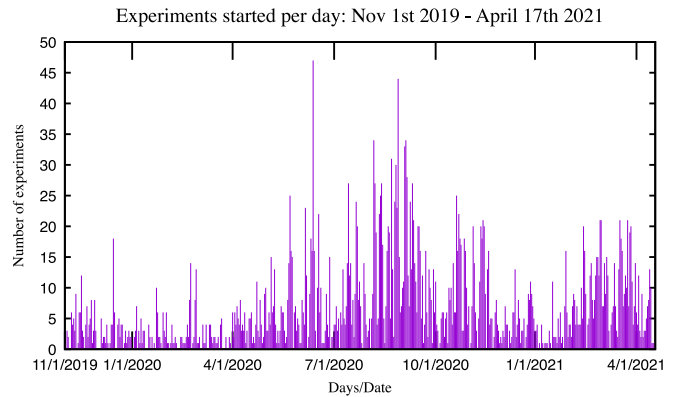

Fig. 21. Number of experiments per day since POWDER became generally available.

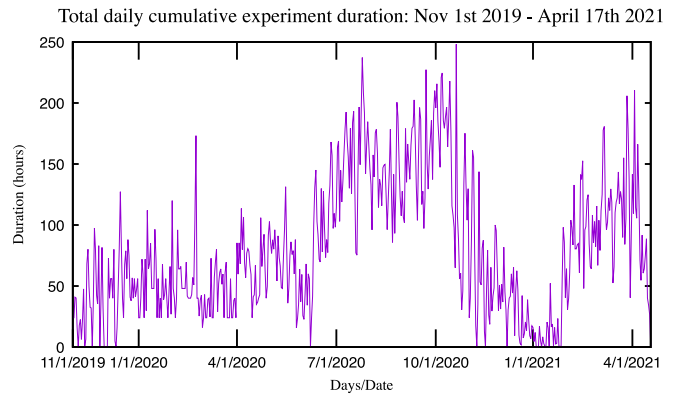

Fig. 22. Cumulative duration of experiments per day since POWDER became generally available.

⁴ In POWDER, a “project” represents a specific research activity that might involve a number of “users”. POWDER “experiments” represent sets of platform resources that are allocated for a period of time (the experiment duration) for users. As such, a user can be associated with multiple projects and can have multiple instantiated experiments.

mobile network performance; RAN orchestration and resource management; alternative RF waveforms, e.g., low power wide area network (LPWAN) and massive MIMO (mMIMO); basestations with quantum-enabled computational techniques; cross-layer-aware RAN scheduling; low-latency networking; localization; spectrum sharing; named-data networking; detecting spectrum offenders; reinforcement learning base

Table 1
POWDER Status & Plans: April 2021.

Area: Functionality	Status	Notes
UofU Campus: Rooftop base stations	Deployed	9 deployed
UofU Campus: Fixed endpoints	Deployed	10 deployment
UofU Campus: Front/back-haul & edge cluster	Deployed	CWDM + 19 compute nodes
Metro Cloud (Campus/downtown datacenter)	Deployed	1200+ Emulab/CloudLab nodes
UofU Campus: Mobile endpoints	In progress	13 deployed, 7 more in progress
Portable endpoints	In progress	Two units available
UofU Campus: Dense deployment	In progress	Deployment expected summer 2021

wireless; wireless network management; wireless/5G security; predicting channel characteristics; optimizing mMIMO antenna functionality; wireless signal classification; aligning wireless simulations with real-world functionality; beam finding and beam steering; creating a radio environment map; RF interference management; high-resolution sensing using mMIMO; network slicing and orchestration; handover management and optimization; and software-defined RAN control. The POWDER website contains descriptions of additional research efforts by platform users [69].

Because POWDER has been operational and available for a relatively short period, we expect that users' research in most of these areas is still ongoing. Published (or publicly distributed) research we are aware of, that used the POWDER platform in some form, includes work on improving the capacity [70] and downlink technology [71] of low power wide area networks; on a steganography-based (covert), private, 5G connectivity-as-a-service approach [72]; in applying ML to emerging open RAN approaches [73]; on offloading augmented reality computation to the mobile edge [74]; for geolocation experimentation [75]; and for automated cellular network management [67]. Our own published research that utilizes POWDER-based experiments includes work on radio access network management [76]; on data-driven wireless resource management [77]; and on data-driven validation of RF propagation models [78].

7. Conclusion

The Platform for Open Wireless Data-driven Experimental Research (POWDER) is a unique city-scale, remotely accessible, end-to-end software defined platform supporting a broad range of wireless and mobile related research. POWDER is operational and available for research and is, at the same time, still undergoing development as we add features and capabilities.

Designing, building and deploying a wireless research platform of the scale of POWDER is by necessity a significant undertaking with plenty of opportunities for "hard learned lessons". These include the need for access to spectrum, the tension between deployability and flexibility, the tradeoff between off-the-shelf and specialized hardware, the need for a "people network" to make progress, the difference between "working in the lab" and "working in the wild", dealing with heat and cold and wet etc. For the benefit of the research community we plan to cover these aspects in detail in future publications.

Declaration of competing interest

The authors declare that they have no known competing financial interests or personal relationships that could have appeared to influence the work reported in this paper.

Acknowledgments

This material is based upon work supported by the National Science Foundation, USA under Grant Number 1827940. We acknowledge the support of the PAWR Project Office, USA, the PAWR Industry consortium, USA and our partners at the University of Utah, USA and in Salt Lake City, USA.

References

- [1] Cisco Systems, Cisco Annual Internet Report (2018-2023) White Paper, 2020.
- [2] J. O'Halloran, Huge uptick in global 5G deployment across 2020, 2020, <https://www.computerweekly.com/news/252493760/Huge-uptick-in-global-5G-deployment-across-2020>.
- [3] U. Gustavsson, P. Frenger, C. Fager, T. Eriksson, H. Zirath, F. Dielacher, C. Studer, A. Pärssinen, R. Correia, J.N. Matos, D. Belo, N.B. Carvalho, Implementation challenges and opportunities in beyond-5G and 6G communication, *IEEE J. Microwaves 1* (1) (2021) 86–100, <http://dx.doi.org/10.1109/JMW.2020.3034648>.
- [4] 6GSymposium, 2020. <https://www.6gworld.com/6gsymposium-fall-2020/>.
- [5] X. Foukas, N. Nikaein, M.M. Kassem, M.K. Marina, K. Kontovasilis, Flexran: A flexible and programmable platform for software-defined radio access networks, in: Proceedings of the 12th International Conference on Emerging Networking EXperiments and Technologies, in: CoNEXT '16, ACM, New York, NY, USA, 2016, pp. 427–441, <http://dx.doi.org/10.1145/2999572.2999599>.
- [6] O-R.A.N. Alliance, O-RAN software community, 2020. <https://www.o-ran.org/software>.
- [7] FCC Seeks Comment on Open Radio Access Networks, 2021. <https://www.fcc.gov/document/fcc-seeks-comment-open-radio-access-networks-0>.
- [8] Federal Communications Commission, FCC Establishes first two innovation zones, 2019, <https://www.fcc.gov/document/fcc-establishes-first-two-innovation-zones>.
- [9] Federal Communications Commission, 3.5 GHz band overview, 2020, <https://www.fcc.gov/wireless/bureau-divisions/mobility-division/35-ghz-b{and}/35-ghz-b{and}-overview>.
- [10] Caroline Gabriel, FCC Chief calls for sharing of federal spectrum, 2012, <http://www.rethink-wireless.com/2012/05/24/fcc-chief-calls-sharing-federal-spectrum.htm>.
- [11] NSF's Spectrum Innovation Initiative, https://nsf.gov/mps/oma/spectrum_innovation_initiative.jsp.
- [12] A. Ghosh, Spectrum Usage Analysis and Prediction using LSTM Networks Master's thesis, University of Utah, 2020, <http://www.flux.utah.edu/paper/298>.
- [13] OpenRAN Begins Work on AI/ML Applications for Radio Management, 2020 <https://telecominfrastructure.com/openran-begins-work-on-ai-ml-applications-for-radio-management/>.
- [14] NSF/Intel Partnership on Machine Learning for Wireless Networking Systems (MLWiNS), 2019. https://www.nsf.gov/publications/pub_summ.jsp?org=NSF&ods_key=nsf19591.
- [15] Qualcomm Technologies, The mobile future of extended reality (XR), 2020, <https://www.qualcomm.com/research/extended-reality>.
- [16] B. Han, Y. Liu, F. Qian, ViVo: Visibility-Aware Mobile Volumetric Video Streaming, Association for Computing Machinery, New York, NY, USA, 2020, <http://dx.doi.org/10.1145/3372224.3380888>.
- [17] O. Kanhere, T.S. Rappaport, Position location for futuristic cellular communications: 5G and beyond, *IEEE Commun. Mag.* 59 (1) (2021) 70–75, <http://dx.doi.org/10.1109/MCOM.001.2000150>.
- [18] B. White, J. Lepreau, L. Stoller, R. Ricci, S. Guruprasad, M. Newbold, M. Hibler, C. Barb, A. Joglekar, An integrated experimental environment for distributed systems and networks, in: Proceedings of the 5th Symposium on Operating Systems Design and Implementation (OSDI), 2002, pp. 255–270.
- [19] D. Raychaudhuri, I. Seskar, M. Ott, S. Ganu, K. Ramachandran, H. Kremo, R. Siracusa, H. Liu, M. Singh, Overview of the ORBIT radio grid testbed for evaluation of next-generation wireless network protocols, in: 2005 IEEE Wireless Communications and Networking Conference, Vol. 3, 2005, pp. 1664–1669, <http://dx.doi.org/10.1109/WCNC.2005.1424763>.
- [20] L. Bertozzolo, L. Bonati, E. Demirors, T. Melodia, Arena: A 64-antenna SDR-based ceiling grid testbed for sub-6 GHz radio spectrum research, in: ACM WiNTECH Proceedings, WiNTECH '19, Association for Computing Machinery, New York, NY, USA, 2019, pp. 5–12, <http://dx.doi.org/10.1145/3349623.3355473>.

- [21] K.R. Dandekar, S. Begashaw, M. Jacovic, A. Lackpour, I. Rasheed, X.R. Rey, C. Sahin, S. Shaher, G. Mainland, Grid Software Defined Radio Network Testbed for Hybrid Measurement and Emulation, in: 2019 16th Annual IEEE International Conference on Sensing, Communication, and Networking (SECON), 2019, pp. 1–9.
- [22] A. Banerjee, J. Cho, E. Eide, J. Duerig, B. Nguyen, R. Ricci, J. Van der Merwe, K. Webb, G. Wong, PhantomNet: Research infrastructure for mobile networking, cloud computing and software-defined networking, *ACM GetMobile* 19 (2) (2015) 28–33, <http://dx.doi.org/10.1145/2817761.2817772>.
- [23] Fed4Fire+ Consortium, Federation for Fire Plus, 2020, <https://www.fed4fire.eu/>.
- [24] Imec, Wireless testbed and officelab, 2020, <https://doc.ilabt.imec.be/ilabt/wilab/index.html>.
- [25] IRIS, IRIS - The software defined radio (SDR) testbed, 2020, <http://iristestbed.eu/>.
- [26] NITlab, NITOS Facility, 2020, <https://nitlab.inf.uth.gr/NITlab/nitos>.
- [27] INRIA Sophia Antipolis, R2lab, 2020. <https://r2lab.inria.fr/index.md>.
- [28] TRIANGLE Project, TRIANGLE Project: 5G applications and devices benchmarking, 2020, <https://www.triangle-project.eu/>.
- [29] H. Soroush, N. Banerjee, A. Balasubramanian, M.D. Corner, B.N. Levine, B. Lynn, DOME: A diverse outdoor mobile testbed, in: Proceedings of the 1st ACM International Workshop on Hot Topics of Planet-Scale Mobility Measurements (HotPlanet), 2009, <http://dx.doi.org/10.1145/1651428.1651431>.
- [30] CORNET, CORNET: Cognitive radio network testbed, 2015, <http://cornet.wireless.vt.edu/>.
- [31] K.-K. Yap, M. Kobayashi, R. Sherwood, T.-Y. Huang, M. Chan, N. Handigol, N. McKeown, Openroads: Empowering research in mobile networks, *ACM SIGCOMM Comput. Commun. Rev.* 40 (1) (2010) 125–126, <http://dx.doi.org/10.1145/1672308.1672331>.
- [32] A. Massouri, L. Cardoso, B. Guillon, F. Hutu, G. Villemaud, T. Risset, J.-M. Gorce, CorteXLab: An open FPGA-based facility for testing SDR & cognitive radio networks in a reproducible environment, in: 2014 IEEE Conference on Computer Communications Workshops (INFOCOM WKSHPS), IEEE, 2014, pp. 103–104, <http://dx.doi.org/10.1109/INFOCOMW.2014.6849176>.
- [33] R. Chandra, T. Moscibroda, P. Bahl, R. Murty, G. Nychis, X. Wang, A campus-wide testbed over the TV white spaces, *ACM SIGMOBILE Mobile Comput. Commun. Rev.* 15 (3) (2011) 2–9, <http://dx.doi.org/10.1145/2073290.2073292>.
- [34] Imec, CityLab, 2020, https://doc.lab.cityofthings.eu/wiki/Main_Page.
- [35] 5G-VINNI Consortium, 5G-VINNI: 5G verticals innovation infrastructure, 2020, <https://www.5g-vinni.eu/>.
- [36] 5GENESIS, 5GENESIS: 5th generation end-to-end network, experimentation, system integration, and showcasing, 2020, <https://5genesis.eu/>.
- [37] PAWR, Platforms for Advanced Wireless Research (PAWR), 2020, <https://advancedwireless.org/>.
- [38] D. Raychaudhuri, I. Seskar, G. Zussman, T. Korakis, D. Kilper, T. Chen, J. Kolodziejski, M. Sherman, Z. Kostic, X. Gu, H. Krishnaswamy, S. Maheshwari, P. Skrimponis, C. Gutterman, Challenge: COSMOS: A city-scale programmable testbed for experimentation with advanced wireless, in: Proceedings of the 26th Annual International Conference on Mobile Computing and Networking (MobiCom), 2020, <http://dx.doi.org/10.1145/3372224.3380891>.
- [39] AERPAW, AERPAW: Aerial experimentation and research platform for advanced wireless, 2020, <https://aerpaw.org/>.
- [40] Flux Research Group, Emulab - network emulation testbed, 2020, <https://www.emulab.net/>.
- [41] Flux Research Group, CloudLab, 2020, <https://www.cloudlab.us/>.
- [42] FABRIC, FABRIC: Adaptive programmable research infrastructure for computer science and science applications, 2020, <https://fabric-testbed.net/>.
- [43] GNU Radio Project, GNURadio: The free and open software radio ecosystem, 2020, <https://www.gnuradio.org/>.
- [44] OpenAirInterface Software Alliance, Openairinterface5G: Openairinterface 5G wireless implementation, 2020, <https://github.com/eurecom/fr/oai/openairinterface5g>.
- [45] Software Radio Systems, SrsLTE: Open source LTE from software radio systems (SRS), 2020, <https://github.com/srsLTE>.
- [46] Free5GC.org, Free5GC: Open source 5G mobile core network, 2020, <https://www.free5gc.org/>.
- [47] OpenAirInterface, OPENAIR-CN: An implementation of the evolved packet core network, 2019, <https://github.com/OPENAIRINTERFACE/openair-cn>.
- [48] Open Network Foundation, Enabling the Smart Enterprise with Private 5G Connectivity + Connected Edge Cloud, <https://aetherproject.org>.
- [49] OpenStack Foundation, OpenStack, 2020, <https://www.openstack.org/software>.
- [50] ONAP, ONAP: Open network automation platform, 2018, <https://www.onap.org/>.
- [51] Open Networking Foundation, CORD: Central office re-architected as a datacenter, 2020, <https://www.opennetworking.org/cord/>.
- [52] C. Shepard, H. Yu, N. Anand, E. Li, T. Marzetta, R. Yang, L. Zhong, Argos: Practical many-antenna base stations, in: Proceedings of the 18th Annual International Conference on Mobile Computing and Networking, MobiCom '12, ACM, 2012, pp. 53–64, <http://dx.doi.org/10.1145/2348543.2348553>.
- [53] RENEW Project Group, RENEW: Reconfigurable eco-system for next-generation end-to-end wireless, 2020, <https://renew.rice.edu/>.
- [54] B.C. Terry, A. Orange, N. Patwari, S.K. Kasper, J. Van der Merwe, Spectrum monitoring and source separation in POWDER, in: ACM WiNTECH Proceedings, 2020, <http://dx.doi.org/10.1145/3411276.3412192>.
- [55] C. Shepard, R. Doost-Mohammady, R.E. Guerra, L. Zhong, Demo: Argosv3: An efficient many-antenna platform, in: Proceedings of the 23rd Annual International Conference on Mobile Computing and Networking, MobiCom '17, ACM, 2017, pp. 501–503, <http://dx.doi.org/10.1145/3117811.3119863>.
- [56] Flux Research Group, POWDER Example profiles, (accessible to logged-in POWDER users), 2020, <https://www.powderwireless.net/example-profiles.php>.
- [57] Federal Communications Commission, Use of the 5.850–5.925 GHz band, 2019, <https://docs.fcc.gov/public/attachments/DOC-360940A1.pdf>.
- [58] T. Kidd, National radio quiet and dynamic zones, CHIPS, the Department of the Navy's Information Technology Magazine (April–2018). <https://www.doncio.navy.mil/CHIPS/ArticleDetails.aspx?ID>.
- [59] S.N. Premnath, D. Wasden, S.K. Kasper, N. Patwari, B. Farhang-Boroujeny, Beyond OFDM: Best-effort dynamic spectrum access using filterbank multicarrier, *IEEE/ACM Trans. Netw.* 21 (3) (2013) 869–882, <http://dx.doi.org/10.1109/TNET.2012.2213344>.
- [60] M. Rice, T. Nelson, J. Palmer, C. Lavin, K. Temple, Space-time coding for aeronautical telemetry: Part ii—decoder and system performance, *IEEE Trans. Aerosp. Electron. Syst.* 53 (4) (2017) 1732–1754, <http://dx.doi.org/10.1109/TAES.2017.2671785>.
- [61] C.R. Anderson, G.D. Durgin, Propagation measurements and modeling techniques for 3.5 GHz radar-LTE spectrum sharing, in: 2017 32nd General Assembly and Scientific Symposium of the International Union of Radio Science (URSI GASS), 2017, <http://dx.doi.org/10.23919/URSISGASS.2017.8105186>.
- [62] M. Ji, R.-R. Chen, Fundamental limits of wireless distributed computing networks, in: IEEE INFOCOM 2018 - IEEE Conference on Computer Communications, 2018, pp. 2600–2608, <http://dx.doi.org/10.1109/INFOCOM.2018.8485811>.
- [63] RENEW Project Group, RENEW Software, 2020, <https://gitlab.renew-wireless.org/renew/renew-software>.
- [64] T.L. Marzetta, Noncooperative cellular wireless with unlimited numbers of base station antennas, *IEEE Trans. Wireless Commun.* 9 (11) (2010) 3590–3600, <http://dx.doi.org/10.1109/TWC.2010.092810.091092>.
- [65] M. Karlsson, E.G. Larsson, On the operation of massive MIMO with and without transmitter CSI, in: 2014 IEEE 15th International Workshop on Signal Processing Advances in Wireless Communications (SPAWC), IEEE, 2014, pp. 1–5, <http://dx.doi.org/10.1109/SPAWC.2014.6941305>.
- [66] E. Björnson, E.G. Larsson, M. Debbah, Massive MIMO for maximal spectral efficiency: How many users and pilots should be allocated? *IEEE Trans. Wireless Commun.* 15 (2) (2016) 1293–1308, <http://dx.doi.org/10.1109/TWC.2015.2488634>.
- [67] L. Bonati, S. D'Oro, L. Bertizzolo, E. Demirors, Z. Guan, S. Basagni, T. Melodia, Cellos: Zero-touch software-defined open cellular networks, *Comput. Netw.* 180 (2020) 107380, <http://dx.doi.org/10.1016/j.comnet.2020.107380>.
- [68] Path loss measurement, 2020, <https://gitlab.flux.utah.edu/powderrenewpublic/mww2019/blob/master/Path%20Loss%20Measurement.md>.
- [69] Powder Enabled Research, 2020. <https://powderwireless.net/use>.
- [70] Z. Zhang, ZCNET: Achieving high capacity in low power wide area networks, in: 2020 IEEE 17th International Conference on Mobile Ad Hoc and Sensor Systems (MASS), 2020, pp. 702–710, <http://dx.doi.org/10.1109/MASS50613.2020.00090>.
- [71] Z. Zhang, MPCast: A Novel Downlink Transmission Technology for Low Power Wide Area Networks, in: IEEE International Conference on Communications, 2021.
- [72] L. Bonati, S. D'Oro, F. Restuccia, S. Basagni, T. Melodia, StealLTE: Private 5G Cellular Connectivity as a Service with Full-stack Wireless Steganography, in: IEEE International Conference on Computer Communications, 2021.
- [73] G. Reus-Muns, D. Jaisinghani, K. Sankhe, K.R. Chowdhury, Trust in 5G open RANs through machine learning: RF fingerprinting on the POWDER PAWR platform, in: GLOBECOM 2020-2020 IEEE Global Communications Conference, 2020, pp. 1–6, <http://dx.doi.org/10.1109/GLOBECOM42002.2020.9348261>.
- [74] P. Zhou, B. Finley, X. Li, S. Tarkoma, J. Kangasharju, M. Ammar, P. Hui, 5G MEC Computation HandOff for Mobile Augmented Reality, 2021, arXiv preprint [arXiv:2101.00256](https://arxiv.org/abs/2101.00256).

- [75] K. Escobar, D. Parker, J. Jacobs, T. Spafford, A. Orange, T. Hahn, D. Detienne, J. Davies, A. Rasmussen, Geolocation on the university of utah POWDER 5g testbed, in: 2020 Intermountain Engineering, Technology and Computing (IETC), 2020, pp. 1–6, <http://dx.doi.org/10.1109/IETC47856.2020.9249066>.
- [76] A. Gottipati, J. Van der Merwe, BoTM: Basestation-on-the-move, a Radio Access Network Management Primitive, in: CNERT: Computer and Networking Experimental Research using Testbeds, 2021.
- [77] K. Webb, S.K. Kasera, N. Patwari, J. Van der Merwe, WiMatch: Wireless Resource Matchmaking, in: CNERT: Computer and Networking Experimental Research using Testbeds, 2021.
- [78] J. Monterroso, J. Van der Merwe, K. Webb, G. Wong, Towards using the POWDER platform for RF propagation validation, in: CNERT: Computer and Networking Experimental Research using Testbeds, 2021.



Joe Breen is a Senior IT Architect at the University of Utah Center for High Performance Computing Center. He focuses on network measurement, network protocols, Software Defined Networking, and optimizing large transfers across the globe. He currently is Co-PI on POWDER focused on infrastructure and Co-PI on SLATE focused on delivery of science applications on federated kubernetes instances around the world. He also serves as the interim chair of the Internet2 Performance Working Group and co-chair of the Community Measurement, Metrics and Telemetry project.



Andrew W. Buffmire is currently a Research Corporate Ambassador working with advanced technologies at the University of Utah (UoU). He works with university researchers across multiple disciplines and private industry to provide a strategic interface between commercial enterprise and technology research including wireless technology research at the university. Mr. Buffmire has been in business development and strategy roles in the telecommunications industry for over 25 years. He was on the launch team and a business development director for Sprint PCS, a Vice President of Business Development for a publicly traded Sprint Affiliate and a Director of Strategy and Business Development in the Unified Communications Group at Microsoft. He was also the founder and CEO of two telecom technology companies backed by Silicon Valley Venture Capital firms and has, most recently, supported the development of industry support for the university's Wide Area Network Platform for Open Wireless Data-driven Experimental Research (POWDER) as part of the National Science Foundation's Platform's for Advanced Wireless Research program.



Jonathon Duerig is a Research Associate in the School of Computing at the University of Utah. He joined the Flux Research Group as a staff member in 2009. His research interests include testbeds, networking, security, and systems. He has a B.S. degree in Computer Science from the University of Utah.



Kevin Dutt Until his recent retirement, Kevin Dutt was a project manager with the Utah Education and Telehealth Network (UETN) at the University of Utah. His prime responsibilities revolved around building out UETN's fiber infrastructure across the state of Utah.



Eric Eide is a Research Associate Professor and Co-director of the Flux Research Group in the School of Computing at the University of Utah. He joined the Flux Research Group as a staff member in 1996, and he became a School of Computing faculty member in 2013. Prof. Eide's research focuses on the engineering of trustworthy systems software: this includes activities toward improving the correctness, testing, resilience, and security of large systems, as well as activities toward improving the rigor and repeatability of computer science experiments. He has co-chaired Artifact Evaluation Committees for the ACM SIGPLAN PLDI and USENIX OSDI conferences, and he is the current chair of the Artifact Evaluation Board for the Journal of Systems Research. Prof. Eide is a Co-PI of the POWDER project, where he is the lead for repeatability concerns and experimenter support.



Anneswa Ghosh is a Software Engineer at Microsoft, Relevance RnD Search team. She graduated with an M.S. degree from The University of Utah and a B.Tech degree from NIT Silchar majoring in Computer Science. Her M.S. thesis titled "Spectrum Usage Analysis and Prediction Using LSTM Networks" studied dynamic spectrum access and spectrum usage prediction system using deep learning. Her research interests span the areas of deep learning, machine learning, and relevance of search results.

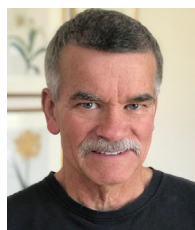

Mike Hibler is a Senior Staff member in the Flux Research Group in the School of Computing at the University of Utah. He has been with the Flux Research Group and its predecessors since 1987 where he has done research and development on operating systems, security, networking, and testbeds. Mike has B.S. and M.S degrees in Computer Science from the New Mexico Institute for Mining and Technology.



David Johnson is a Research Associate and software engineer in the Flux Research Group in the School of Computing at the University of Utah. He joined the Flux Research Group as a staff member in 2006 and completed his M.S. degree in Computer Science in 2010. His research encompasses a broad range of systems software: mobile and wired networks, cloud computing, security, and operating systems.



Sneha Kumar Kasera is the Associate Dean for Academic Affairs in the College of Engineering and a Professor in the School of Computing at the University of Utah in Salt Lake City. From 1999–2003, he was a member of technical staff in the Mobile Networking Research Department of Bell Laboratories. Earlier, he received a Ph.D. in Computer Science from the University of Massachusetts Amherst, and a Master's degree in Electrical Communication Engineering from the Indian Institute of Science Bangalore. Dr. Kasera's research interests include computer networks and systems encompassing mobile and pervasive systems and wireless networks, network security and privacy and reliability, Internet of things, crowdsourcing, dynamic spectrum access, software-defined networks, network resource management, network measurements, and modeling. He is a recipient of the 2019 R&D 100 award for his work on real-time radio frequency signal detection and classification, and the 2002 Bell Labs President's Gold Award for his contribution to wireless data research. He has served as the program chair of IEEE WoWMoM in 2020, ACM WiSec in 2017, ACM MobiCom in 2015, and the IEEE ICNP and IEEE SECON conferences in 2011. He has also served on the editorial boards of the IEEE Transactions on Mobile Computing, IEEE/ACM Transactions on Networking, ACM MC2R, ACM/Springer WINET, and Elsevier COMNET journals. Prof. Kasera started, and has been leading, the Advanced Networked Systems Research Lab at the University of Utah since 2003. He is the

founding director of the Master of Software Development degree program for non computer science majors at the University of Utah.



Earl Lewis is a senior project manager in the central IT department of the University of Utah. He's been with the University for 18 years managing a wide range of technology infrastructure projects including design and construction of a new data center, design and construction of a fiber optic network connecting the data center to campus, relocation of critical network infrastructure and dozens of network and security related projects. Recently Earl has managed IT infrastructure projects related to construction of new buildings where he acts as a liaison between the Campus Planning, Design and Construction group and the architects and engineers.



Dustin Maas is a Research Associate in the Flux Research Group at the University of Utah School of Computing. Prior to joining Flux, Dustin was the CTO at XANDEM, a company building security and home automation products using RF-sensing technologies. His research is focussed on using physical-layer measurements in wireless networks to understand and respond to changes in the RF environment. Dustin received his B.S. and M.S. degrees in electrical engineering in 2010, followed by a Ph.D. in 2013, all from the University of Utah.

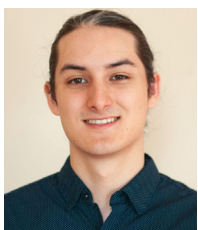

Caleb Martin is currently a masters student at Washington University in St. Louis, studying systems science and mathematics. He completed his B.S. in math at the University of Puget Sound as well as his B.S. in systems science and engineering degree at Washington University. He is currently working in the SPAN Lab under Dr. Neal Patwari, conducting research on RF localization using the Powder wireless platform.



Alex Orange is a Research Associate with the Flux Research Group at the University of Utah School of Computing. He has a B.S. in Electrical Engineering from Northern Arizona University and is a PhD student at the University of Utah. His research area includes RF and Microwave circuits, components, and antennas.



Neal Patwari is a Professor in the McKelvey School of Engineering at Washington University in St. Louis, in both the Dept. of Electrical and Systems Engineering and the Dept. of Computer Science and Engineering. He was previously at the University of Utah in Electrical and Computer Engineering. He investigates statistical signal processing and wireless networking, as well as how algorithmic systems can interact to reinforce societal inequities. His research perspective was shaped by his BS and MS in EE at Virginia Tech, his past work at Motorola Labs, and his Ph.D. in EE at the University of Michigan. He received the NSF CAREER Award in 2008, the 2009 IEEE Signal Processing Society Best Magazine Paper Award, and the 2011 U. of Utah Early Career Teaching Award. He has co-authored papers with best paper awards at SenseApp 2012 and IPSN 2014. Neal has served on technical program committees for IPSN, MobiCom, SECON, IPIN, and SenSys.



Daniel Reading is a Systems Administrator with the Flux Research Group in the University of Utah's School of Computing. Since joining the Flux Group in 2008, Dan has helped to deploy, operate, and maintain the Group's public testbed infrastructures including Emulab, CloudLab, Apt, PhantomNet, and most recently, POWDER.



Robert Ricci is a Research Associate Professor in the School of Computing at the University of Utah, and one of the directors of the Flux Research Group. He works in infrastructure: the systems underneath the software and services that we use everyday. He has published in operating systems, networking, distributed systems, cloud computing, and more. Infrastructure is a very empirical field, requiring lots of implementation and experimentation, so he has also spent the last two decades building testbeds for research; currently, this primarily means the POWDER mobile wireless network testbed (<https://powderwireless.net>) and the CloudLab facility for cloud computing research (<https://cloudlab.us>).



David Schurig received the B.S. degree in engineering physics from the University of California at Berkeley, Berkeley, CA, USA, in 1989, and the Ph.D. degree in physics from the University of California at San Diego, La Jolla, CA, in 2002. He joined the Lawrence Berkeley Laboratory, Berkeley, where he was involved in laser ablation and photoacoustic spectroscopy. After enrolling in graduate school and performing many unpublished experiments, he submitted a theoretical thesis on negative index media, the perfect lens, and related structures. He was with Tristan Technologies, San Diego, CA, where he designed and built cryogenically cooled superconducting quantum interference device-based instruments. He joined Duke University, Durham, NC, USA, where he was supported by the Intelligence Community Postdoctoral Fellowship Program. He was briefly an Associate Professor with the Electrical and Computer Engineering Department, North Carolina State University, Raleigh, NC. In 2011, he joined the Electrical and Computer Engineering Department, The University of Utah, Salt Lake City, UT, USA.



Leigh Stoller is a senior research staff member in the Flux Research Group in the School of Computing at the University of Utah. He has been with the School of Computing since 1986, and worked for various research groups, in areas of languages, compilers, operating systems, networking. Leigh is the principal software architect of POWDER's control framework and web portal. Leigh has B.S. and M.S. degrees in Computer Science from the University of Utah.



Allison Todd is a current undergraduate student at Washington University in St. Louis, studying Electrical Engineering and minoring in Computer Science and Ancient Studies. She is currently working in the SPAN Lab under Dr. Neal Patwari, conducting research on environmental weather conditions and RF communication using the Powder wireless platform.



Jacobus (Kobus) Van der Merwe is the Jay Lepreau Professor in the School of Computing and Director of the Flux Research Group at the University of Utah. He joined the University of Utah in 2012 after fourteen years at AT&T Labs - Research. He does networking systems research in a broad range of areas including network management, control and operation, mobile and wireless networking, network evolution, network security and cloud computing. He is the PI and Director of the POWDER project (Platform for Open Wireless Data-driven Experimental Research), one of the NSF PAWR platforms.



Naren Viswanathan received the Ph.D. degree in electrical engineering researching millimeter-wave computational imaging and massive MIMO antenna arrays with The University of Utah, Salt Lake City, UT, USA, in 2021, under the guidance of Prof. David Schurig. He is currently an Analog engineer at Intel Corporation. His research interests include electromagnetics, antenna design, signal integrity, and computational imaging.



Kirk Webb is a Research Associate with the School of Computing and Associate Director of the POWDER project at the University of Utah. He has a combined fourteen years of experience with the Flux Research Group as a developer and architect of network, cloud, and wireless testbed systems. Kirk has B.S. and M.S. degrees in Computer Engineering and Computer Science (respectively) from the University of Utah. His research interests include wireless propagation, resource matching, and software defined systems.



Gary Wong is a Research Associate in the University of Utah's School of Computing, where he performs systems programming and research support for wired and wireless network testbeds. His research interests include operating system kernels, networking, and compilers, and he holds a BSc degree from the University of Auckland.